



VB-10

*PR SC201 MM (VB-10) Off Road 1/10 2WD Short Course Truck Kit
ITEM NO:69000020*



PR SC201 MM (VB-10) Off Road 1/10 2WD Short Course Truck Kit

Specifications

- Motor: Electric
- Chassis Kick-up: 25-degrees
- Hardware: Full metric
- Bearings: Shields Metal Ball Bearings
- Wheels : Wheels with 12mm hex (front and rear)
- Spur Gear: 73-75-77-(81)-83-tooth 48-Pitch
- Drivetrain:2WD(MM)
- Motor: Electric 540-sized
- Kit/RTR: Kit
- Shock Type: Oil-Filled Aluminum Shocks
- Body: (Clear)
- Driveshafts: Full set of 2 CVA
- 1/10 SC Tires, inserts
- Width: 296 mm
- Weight: 1000-1100g (weight varies with choice of electronics, tires & body)
- Wheelbase: 325mm-329mm
- Gear Ratio: 2.6:1
- Battery choice: 7.4V/4000-6000mAh approx,
- Minimum Age Recommendation: 14 years old

Items required

- Metric 1.5mm, 2.0mm hex tools
- Metric 5.5mm, 7.0mm Nut Driver
- 2 Channel Surface Radio System (Minimum)
- 1/10 ESC, Motor & Pinion Gear
- High-Speed Servo
- 2S LiPo Battery & Compatible Lipo Charger
- Polycarbonate Paint for Bodies
- Tires CA Glue
- Silicon diff oil
- LOK threadlocker

TOOLS REQUIRED

CAUTION: Handle tools carefully!

- Needle Nose Pliers

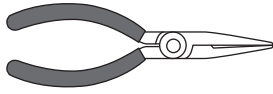

- Awl

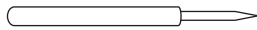

- Grease



- Screw Cement



- Round Cutter & Sander

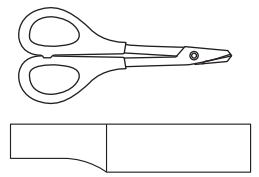

- Sharp Hobby Knife

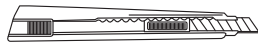

- Wire Cutters



For trimming bodies Cutting along curved lines was never so easy!

- Hex Wrench

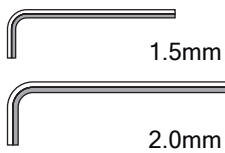

- Ball Differential Grease



- SP Knife Edge Reamer

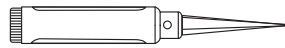

- Cross Wrench

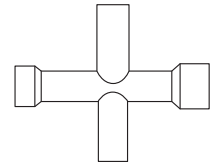

Do not pre-drill as precise drilling of 1mm to 15mm holes can be performed after body shell painted.

RADIO PREPARATION

- A new battery must be charged before it is used. Refer to the charger instruction manual for charging.
- Set up the radio control system as indicated below.

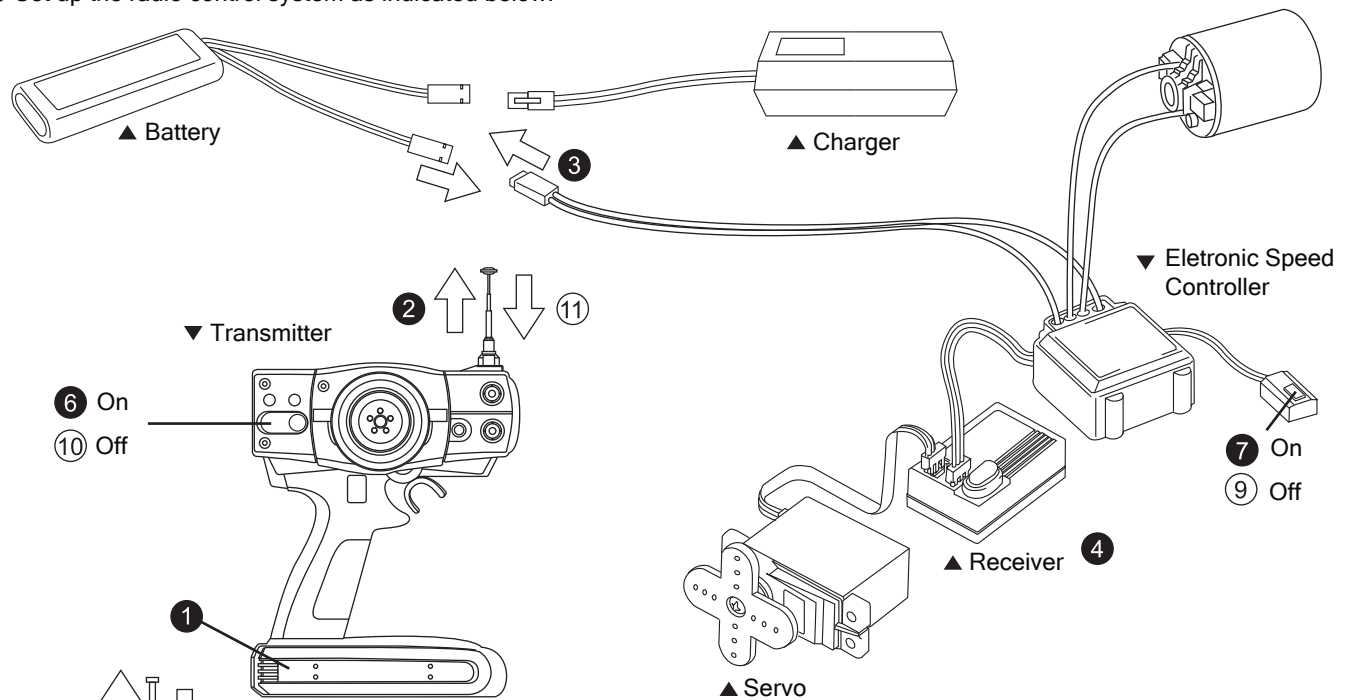

START

- 1 Install batteries.(Transmitter)
- 2 Extend the antenna.(Transmitter)
- 3 Connect the battery to the ESC.
- 4 Extend the antenna.(Receiver)
- 5 Center the trims.
- 6 Switch on both the transmitter and receiver.
- 7 Make sure the servos are in command.

FINISH

- 8 Switch off both the transmitter and receiver.
- 9 Retract the antenna.(Transmitter)

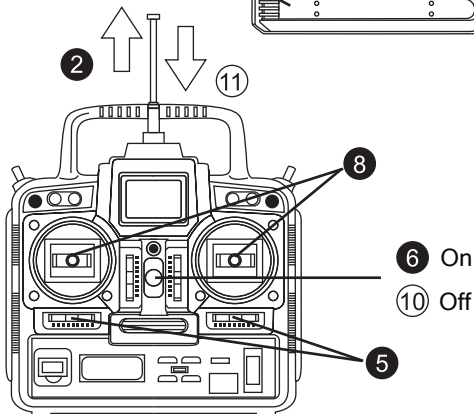

- **BAG A** ----- 03-06
 - Chassis Guard Installation
 - Servo Saver
 - Steering Servo
- **BAG B** ----- 07-10
 - Front Spindle-Right Side
 - Front Suspension[Left Side]
 - Front Shock Stay
 - Front Upper Turnbuckle Assembly
 - Front Bumper Set
 - Turnbuckle Assembly-Steering Rod
- **BAG C** ----- 10-12
 - Rear Chassis Brace (Mid Motor)
 - Battery Column
 - Rear Hub & CVD
 - Rea Suspension Mount
- **BAG D** ----- 13-15
 - Differential Gear
 - Motor Mounts [Mid Motor]
 - Rear Body Mount Set
- **BAG E** ----- 16-20
 - Front & Rear Shock Assembly
 - Motor Guard set
 - Rear Bumper Set
 - Battery Plate
 - Tires
- **SPARE PARTS & OPTIONAL PARTS** ---- 21-22

BEFORE INSTALLATION

- 1 Read through the instruction manual before installation in order to have an overview of what to do.
- 2 Check if there is any missing bags or defective parts, if there is, please contact our local dealer or our PR Distributor.
- 3 Symbols used throughout the instruction manual, comprises of:



Part bags used.



Assemble as many times as specified (here: twice).



Tighten securely.



Note the direction.



True-to-scale diagram.



Do not over tighten.



Must be purchased separately.



Apply threadlocker (screw cement)



Ensure smooth non-binding movement while assembling.



Assemble in the specified order.



Apply grease.



Cut off shaded portion.



Assemble left and right sides the same way.





Apply oil.

- 4 This kit contains screws and hardware in different metric sizes and shapes. Before using them, check the screws on the true-to-scale diagrams on the left side in each assembly step. Some screw are extras.

A1 Chassis Guard Installation

BAG A

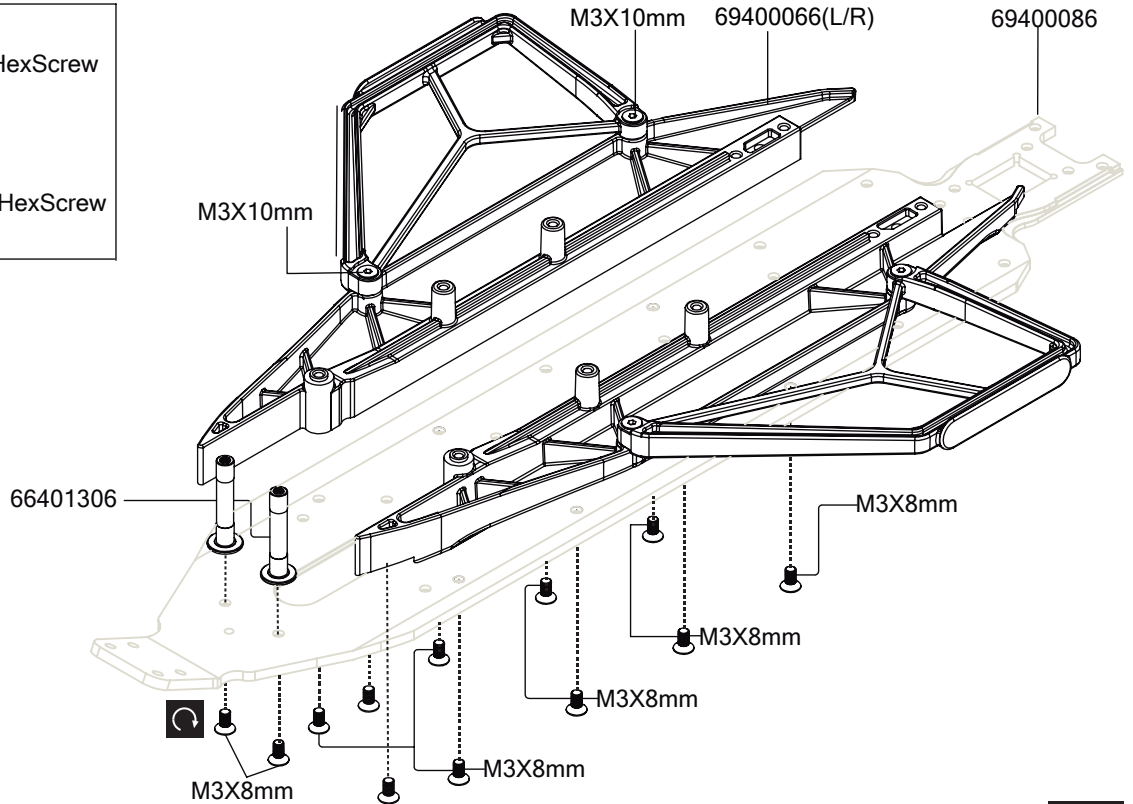

-  12
M3x8mm Flat Head HexScrew
82400026
-  4
M3x10mm Flat Head HexScrew
82400106



L
R

A2 Servo saver

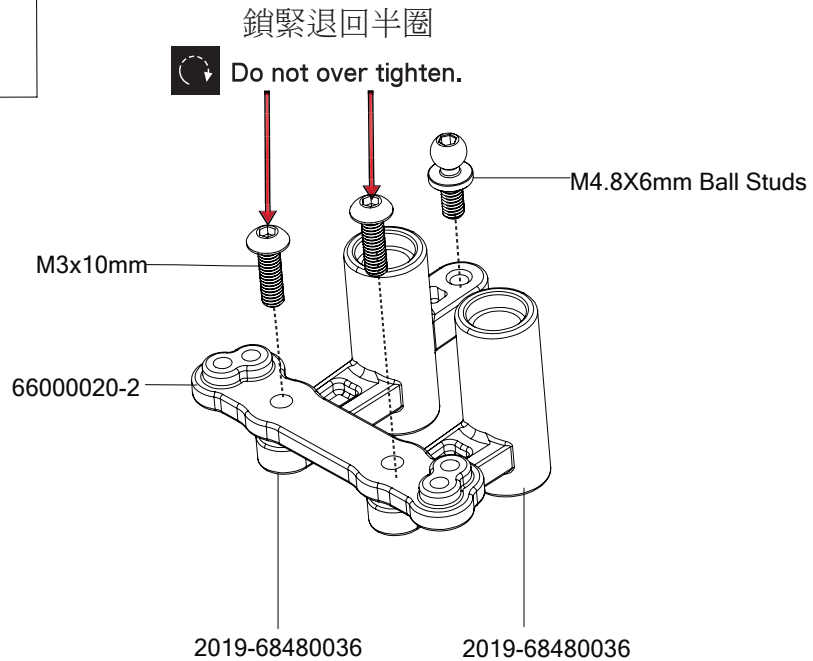

BAG A

-  2
M3X10mm Button Head Cap Screw
80400046
-  1
M4.8X6mm Ball Studs
68430036







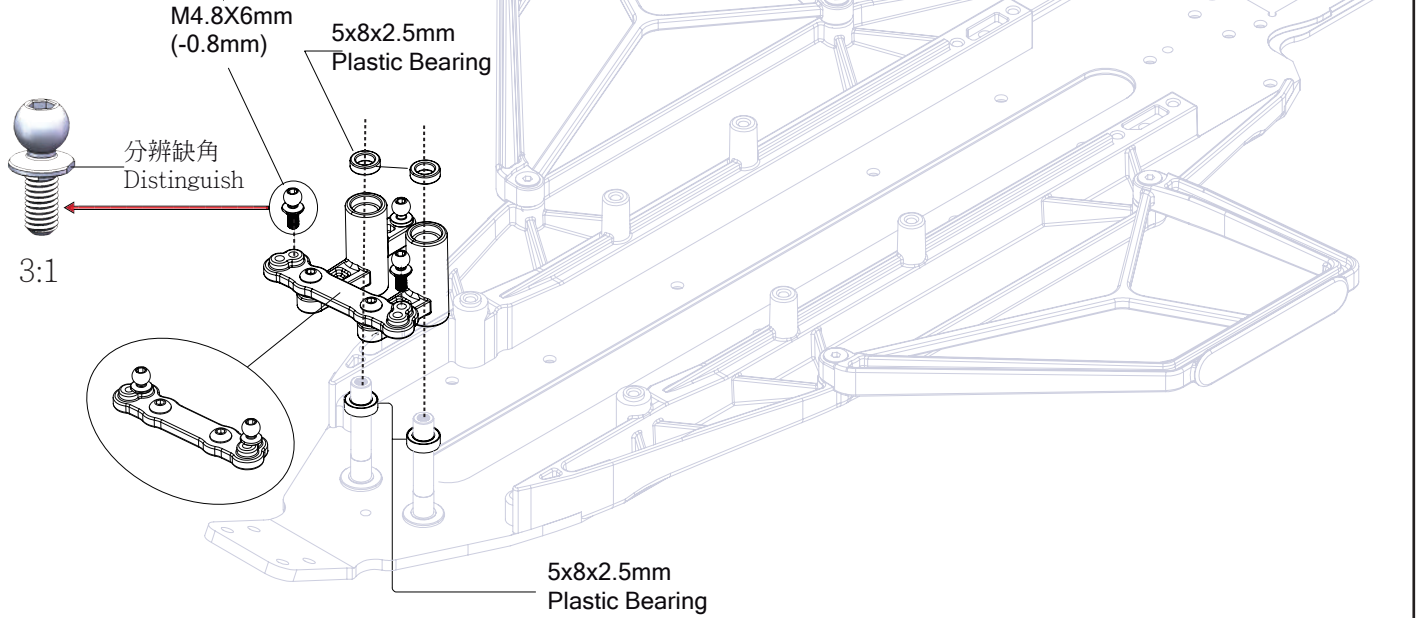

A3 Servo saver

-  2
68430086- M4.8X6mm(-0.8mm)
-  4
66402106-5x8x2.5mm Plastic Bearing



A4 Steering Servo

-  1
M3x10mm Set Screw-8740026
-  1
M4.8mmx6mm Ball Studs-68430036
-  1
M3x10mm Flat Head Hex Screw-82400106
-  1
M3 Nut 83480016

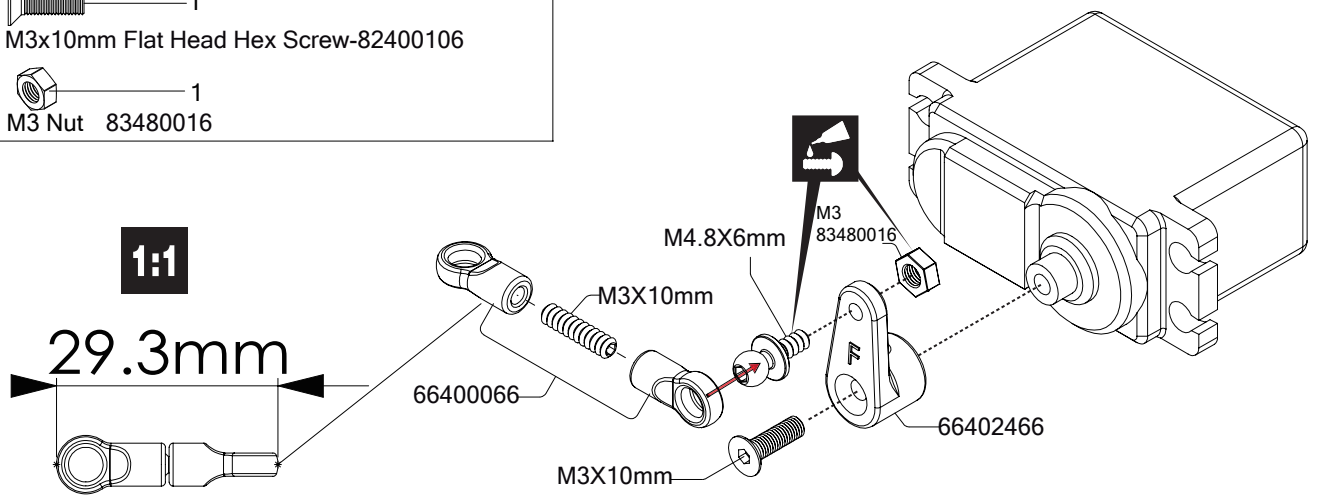

Part Bags used.



True-to-scale diagram.



Apply threadlocker (screw cement)



A5 Steering Servo



4
M3X8mm Button Head Hex Screw
80400036

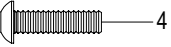

4
80400046
M3X10mm Button Head Hex Screw

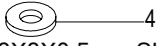

4
3X8X0.5mm Shim
85000010

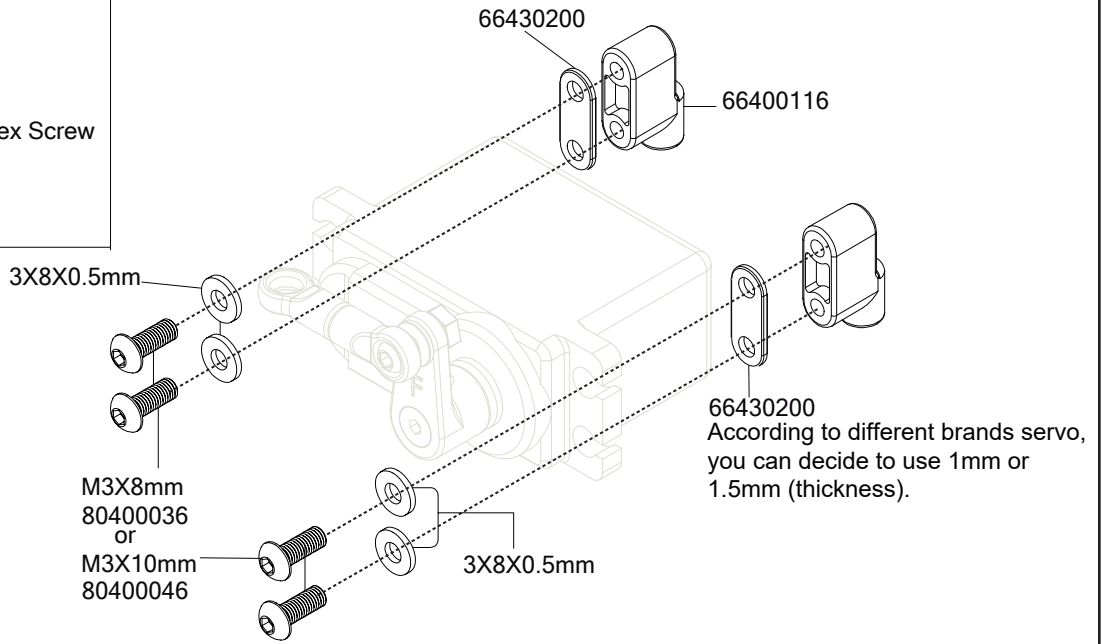
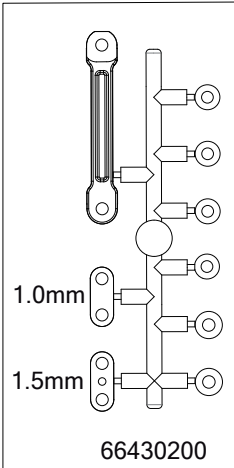

A6 Steering Servo

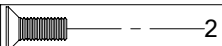

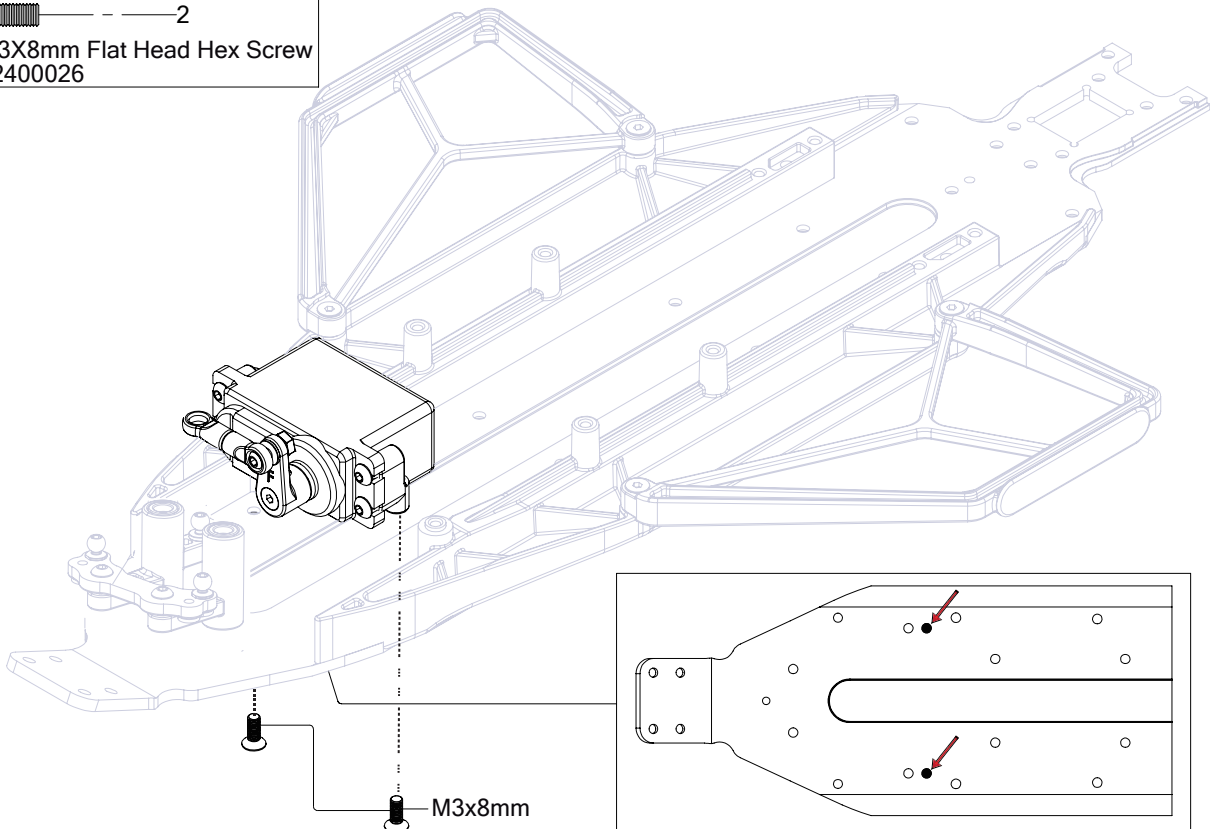

2
M3X8mm Flat Head Hex Screw
82400026





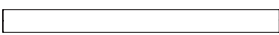

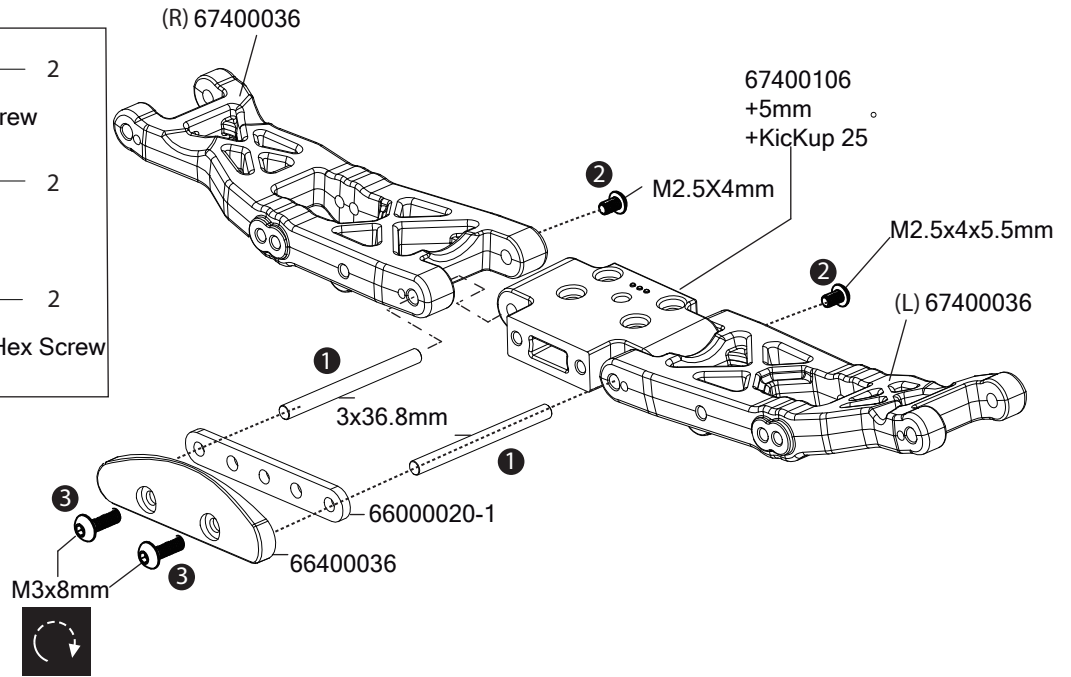

B1 Front Suspension

-  2
3X8mm Button Head Hex Screw
80400036
-  2
3x36.8mm Pin
66430110
-  2
2.5x4x5.5mm Button Head Hex Screw
80400016



B2 Front Spindle[Left Side]

-  2
Steering Screw Stepped -66401686
-  1
M4.8mmx6mm Ball Studs-68430036
-  1
M4.8x10mm Ball Studs- 68430076
-  2
5x10x4mm ZZ Ball Bearing
89430010

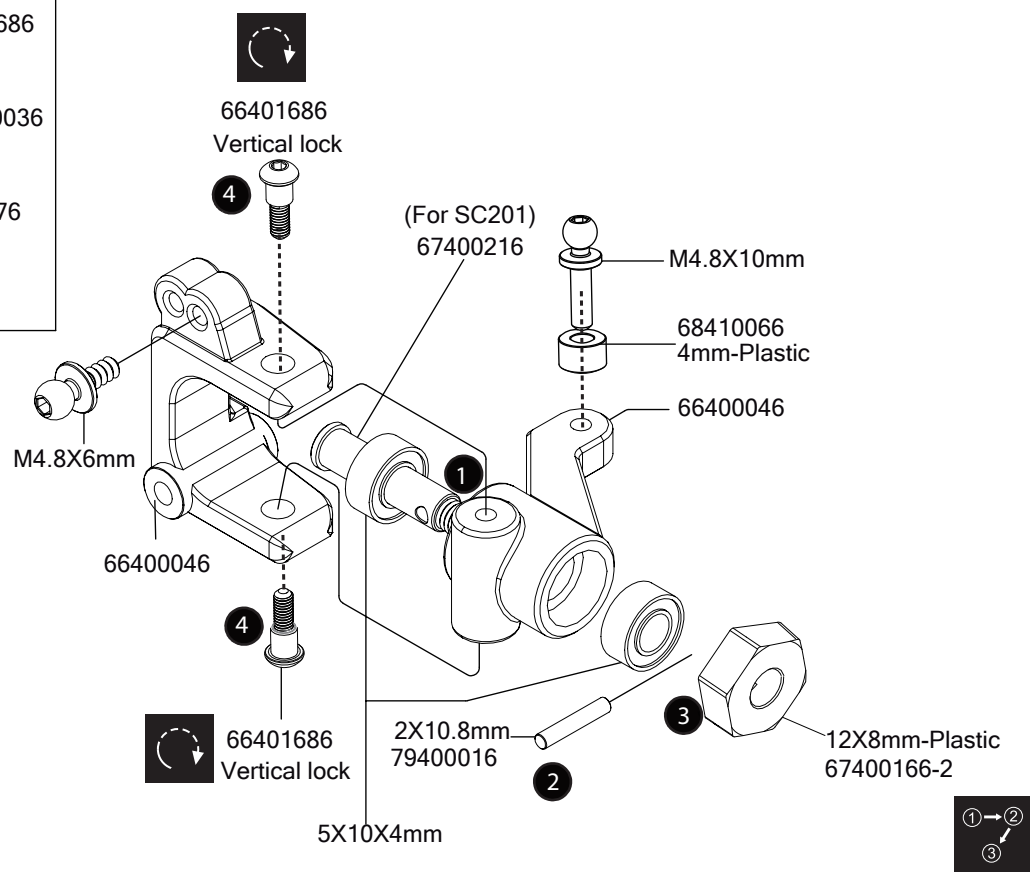

B3 Front Spindle[Right Side]



- 2
Steering Screw Stepped -66401686
- 1
M4.8mmx6mm Ball Studs-68430036
- 1
M4.8x10mm Ball Studs- 68430076
- 2
5x10x4mm ZZ Ball Bearing
89430010

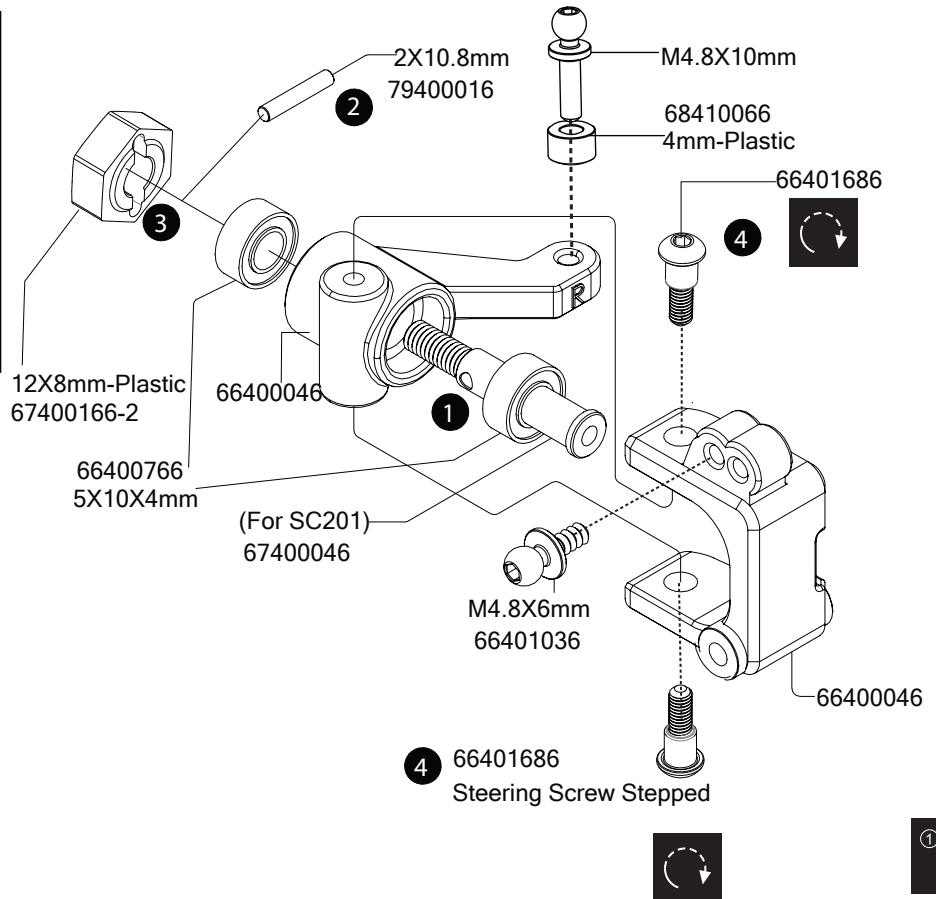

B4 Front Suspension[Left Side]



- 2
M2.5x4x5.5mm
80400016
- 2
3x27.8mm Pin
79400106

Please modify elasticity by this screw.
For swing arm smooth

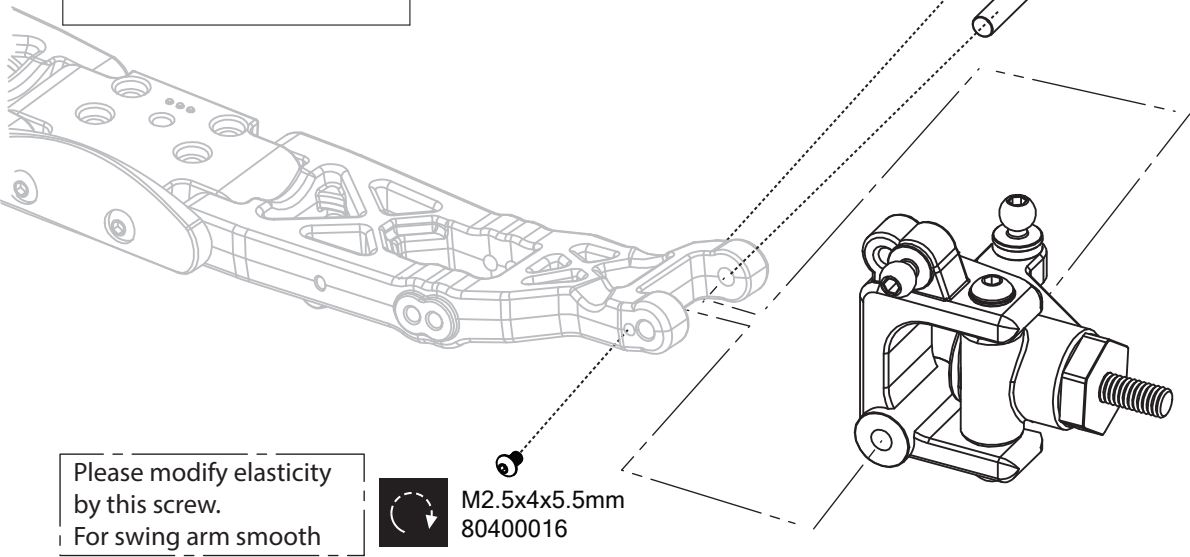
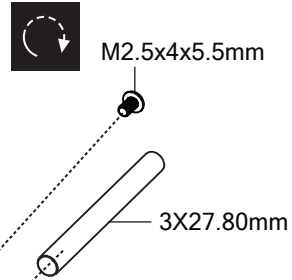

Please modify elasticity by this screw.
For swing arm smooth



Part Bags used.



Assemble in the specified order.



Assemble left and right sides the same way.









Do not over tighten.



B5 Front Shock Stay



-  2
M3x10mm Flat Head Screw
82400106
-  2
M3x12mm Flat Head Screw
82400036
-  6
M3x12mm Button Head Hex Screw
80400206
-  2
M3x18mm Button Head Hex Screw
80400196
-  2
M4.8x6mm Ball Studs
68430036
-  2
M3 Lock Nut
83480026

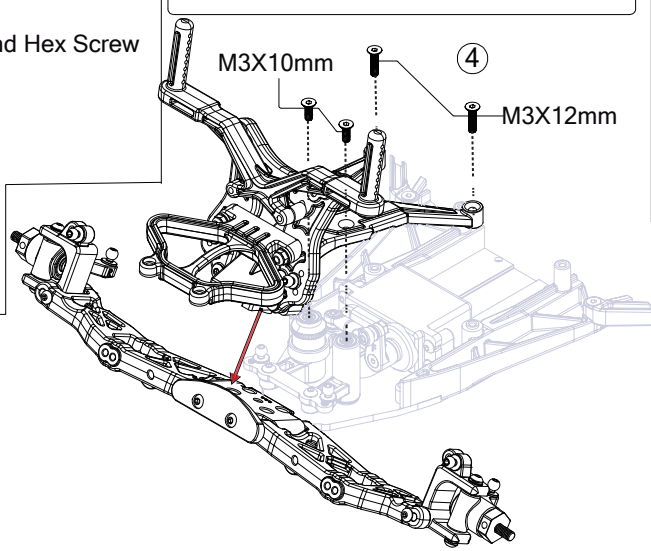
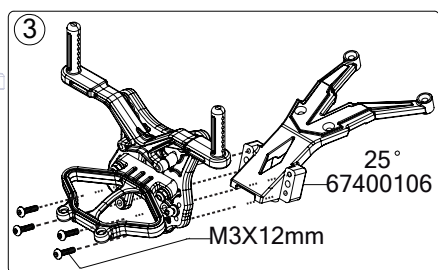
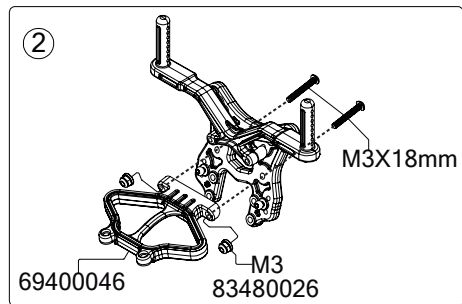
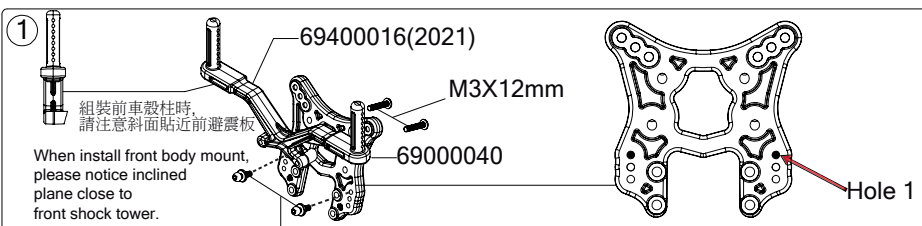

B6 Front Upper Turnbuckle Assembly



29.5mm

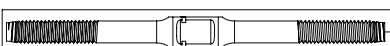
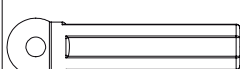

1:1

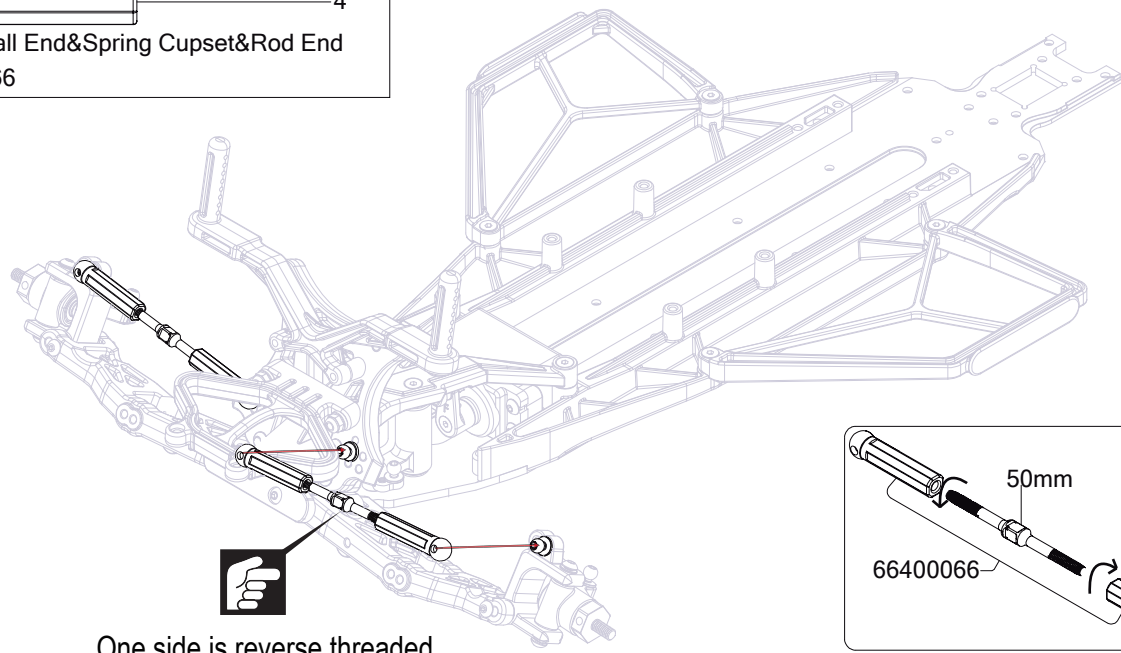
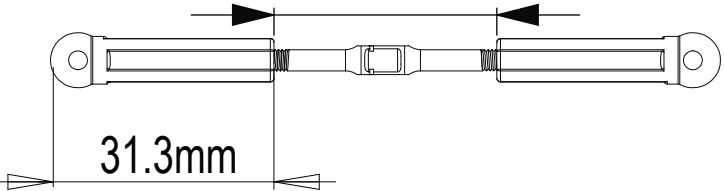
-  2
50mm Turnbuckle Rods
67410026
-  4
Shock Ball End&Spring Cupset&Rod End
66400066





B7 Front Bumper Set

-  2
M3X10mm Flat Head Hex Screw -82400106
-  4
M3X14mm Flat Head Hex Screw -82400046
-  2
M3X18mm Flat Head Hex Screw -82400126

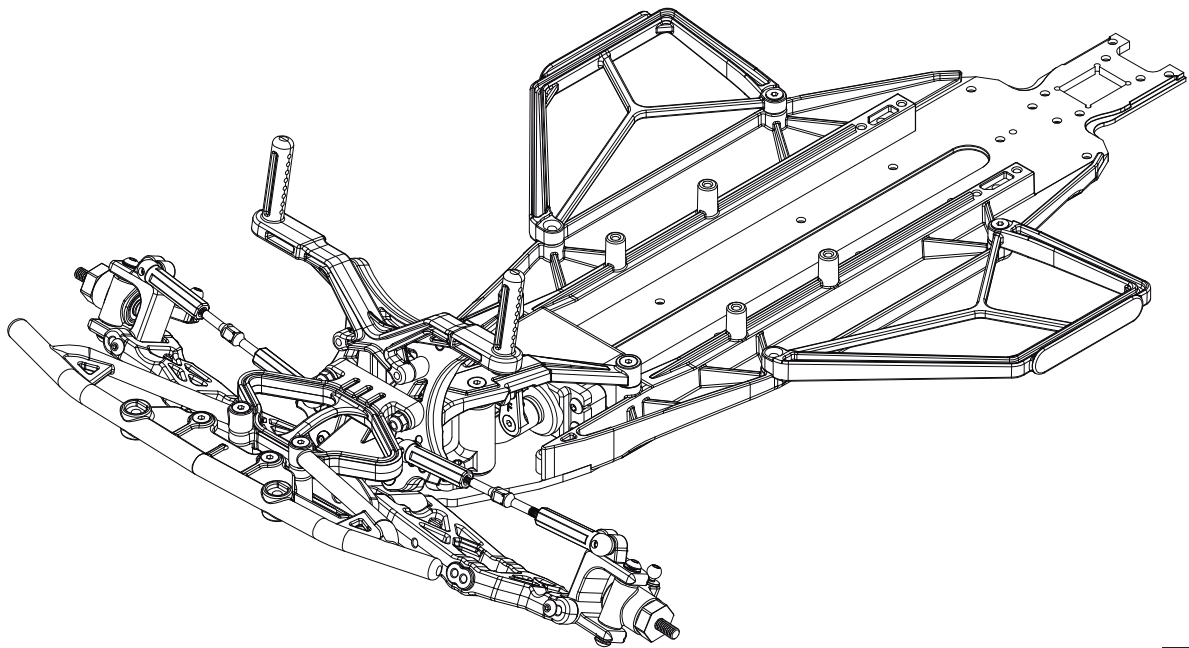
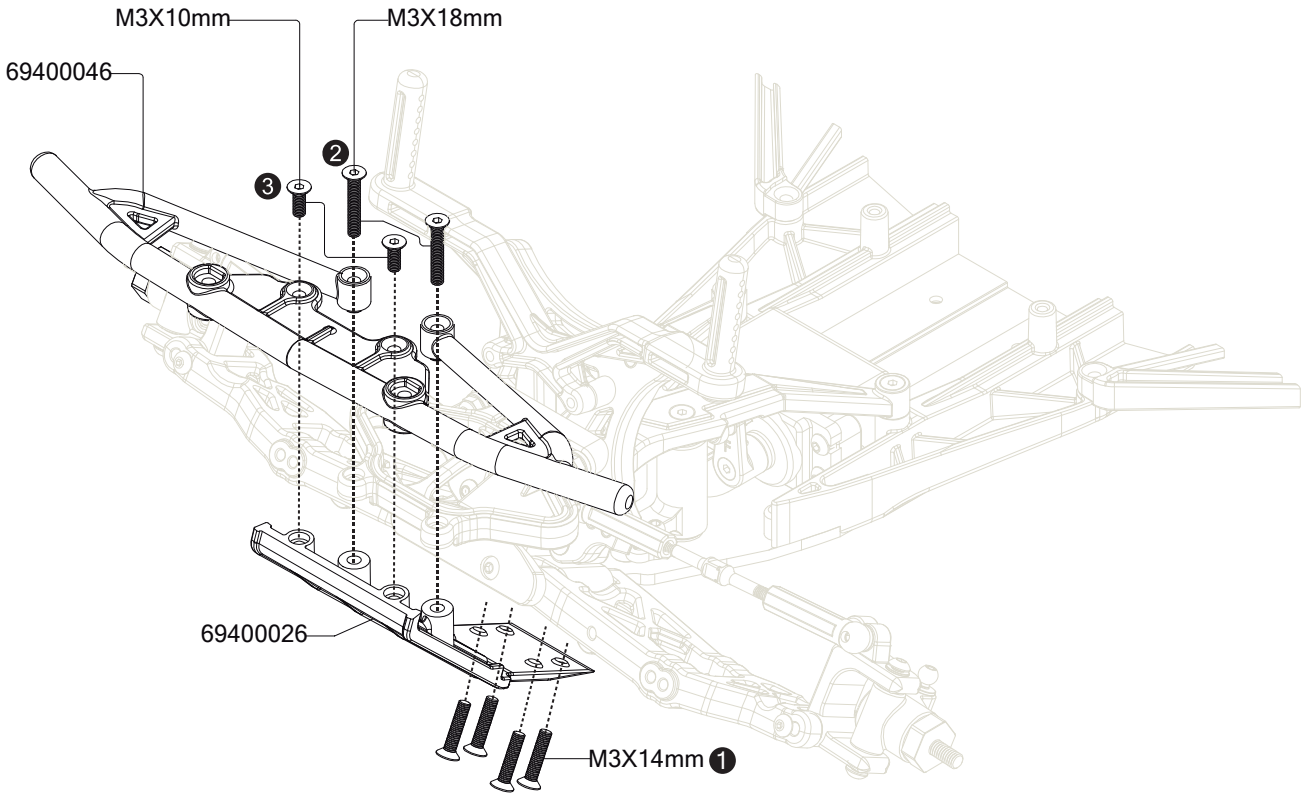
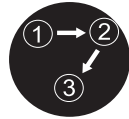



B8 Turnbuckle Assembly-Steering Rod

BAG B

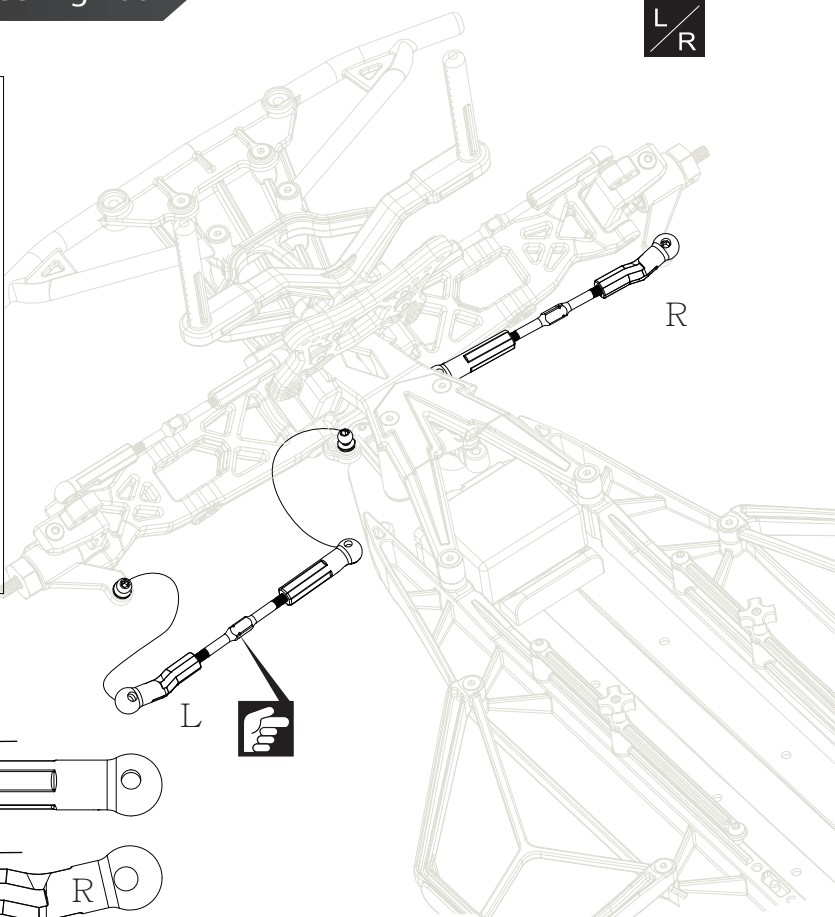
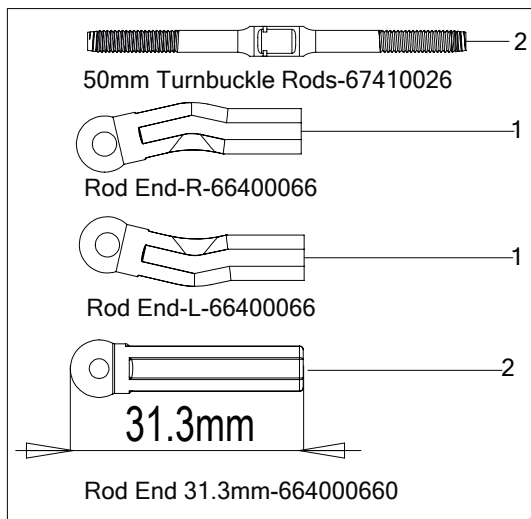

1:1

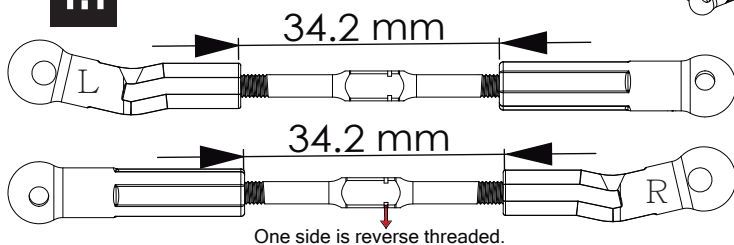

C1 Rear Chassis Brace (Mid Motor)

BAG C

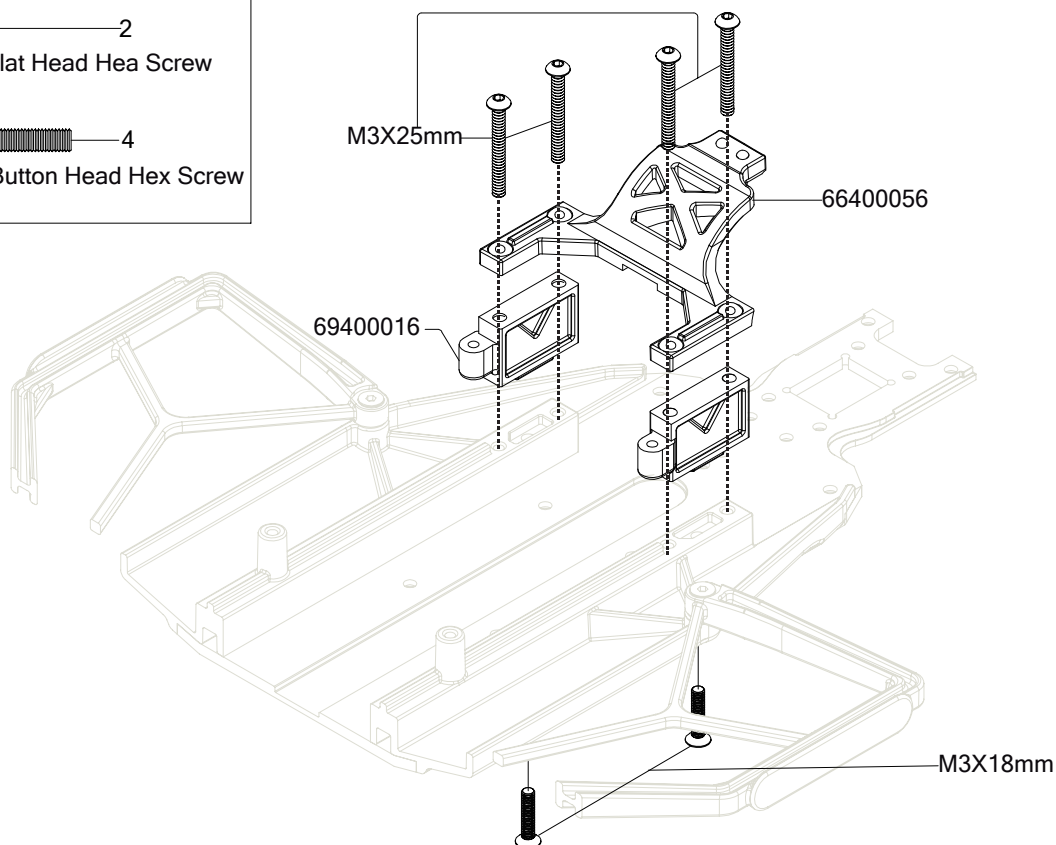
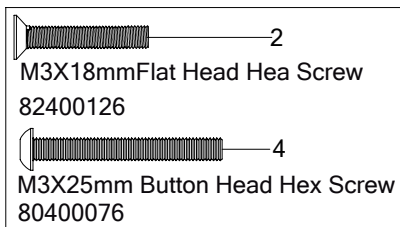

C2 Battery Column

BAG C

2
M3X20mm Set Screw
87400086

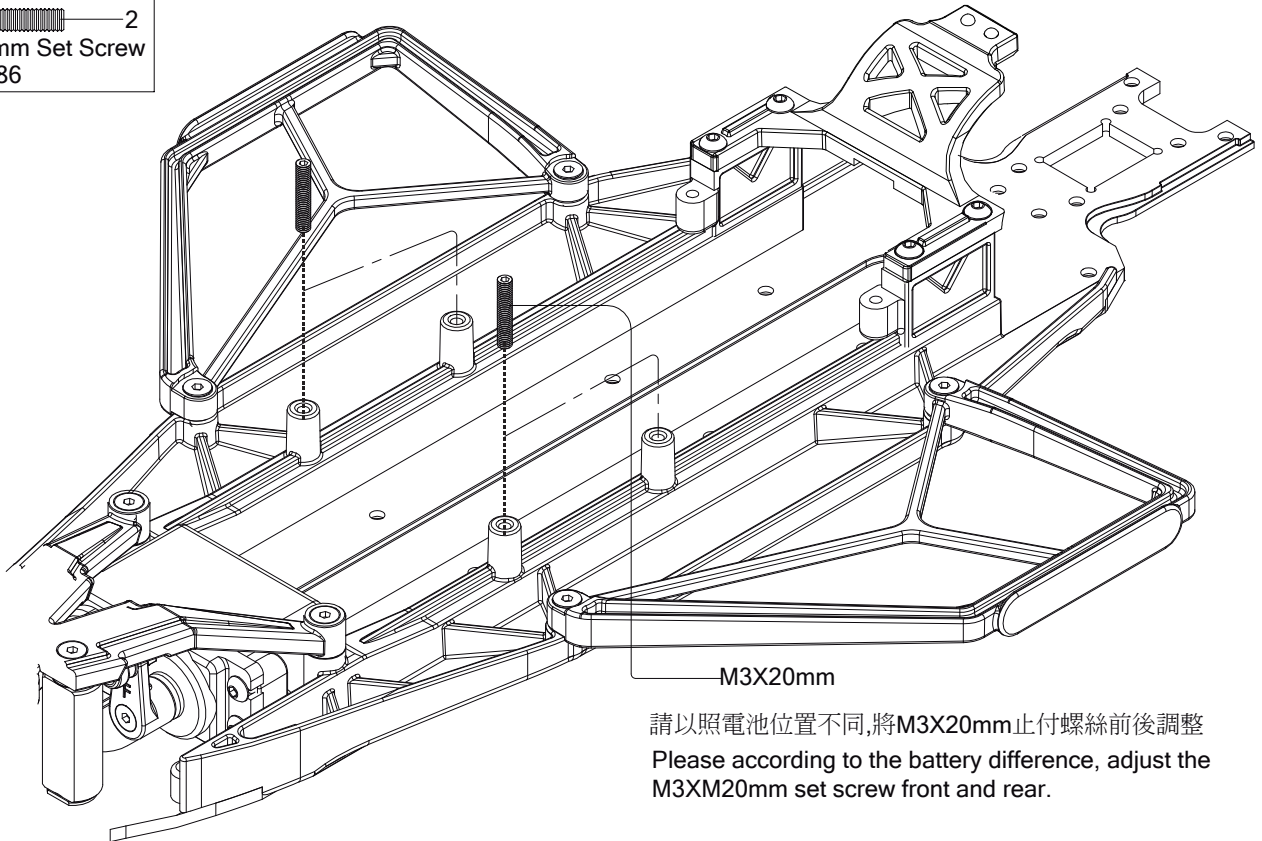

請以照電池位置不同,將M3X20mm止付螺絲前後調整
Please according to the battery difference, adjust the M3XM20mm set screw front and rear.

C3 Rear Hub & CVD

BAG C

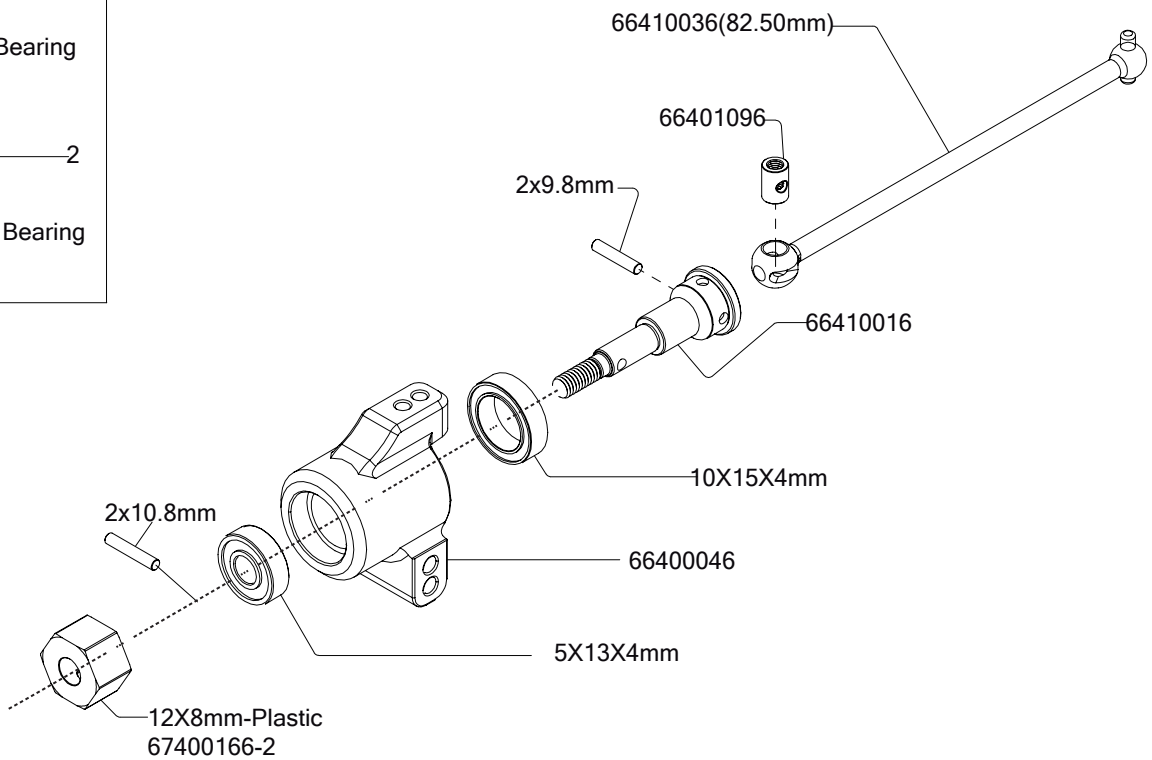
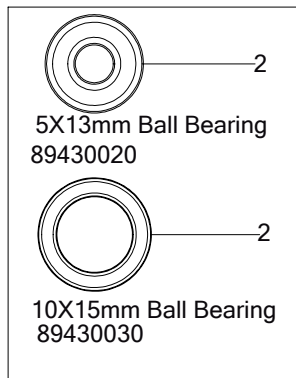

x2 L/R





C4 Rear Hub

BAG C

-  2
M2.5x4x5.5mm Button Head Hex Screw
80400016
-  2
3x36.8mm pin-66430110

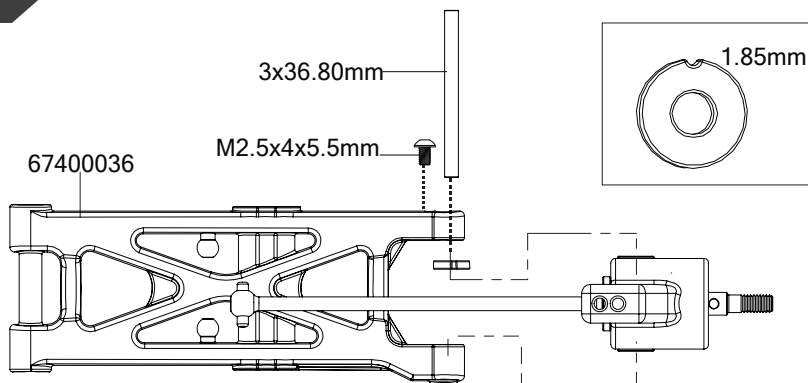

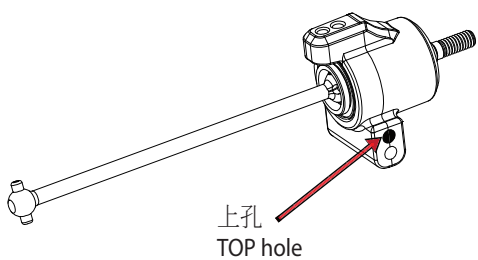

Fornt
車頭



C5 Rea Suspension Mount

BAG C

-  4
M3X8mm Flat Head Hex Screw
82400026
-  2
3X47.5mm-66430120
-  2
85440320
3X8X0.15mm Washer

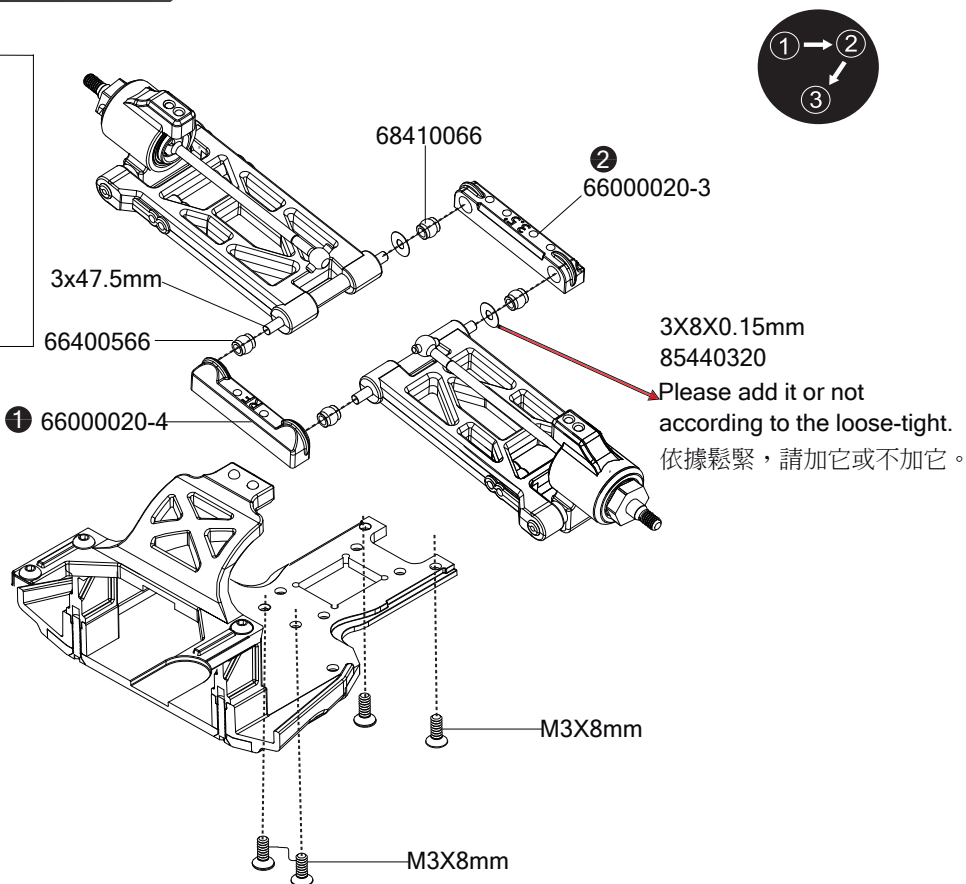



D1 Gear Differential

4 8000021
M2.5X18mm Flat Head Screw

2
5X8x0.8mm Shim
85440170

2
4X10x0.15mm Shim
85440160

2
3.5mmE buckle
85400016

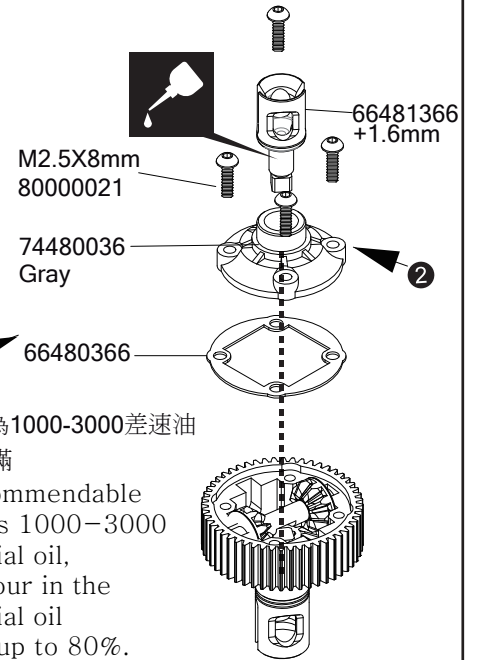
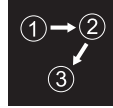
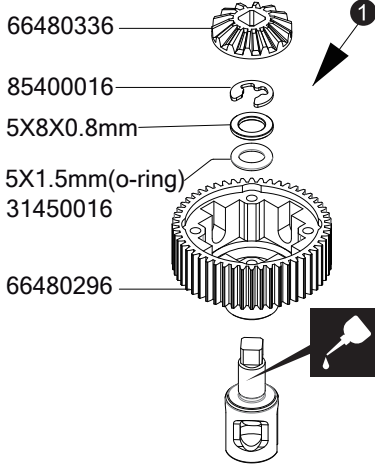

建議濃度為1000-3000差速油
灌至八分滿
The recommendable
density is 1000-3000
differential oil,
please pour in the
differential oil
reached up to 80%.

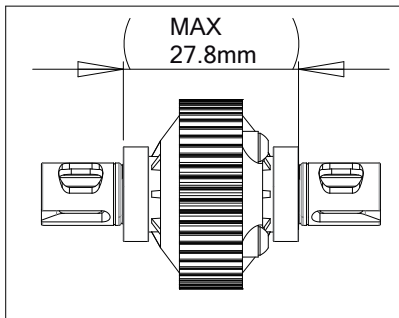
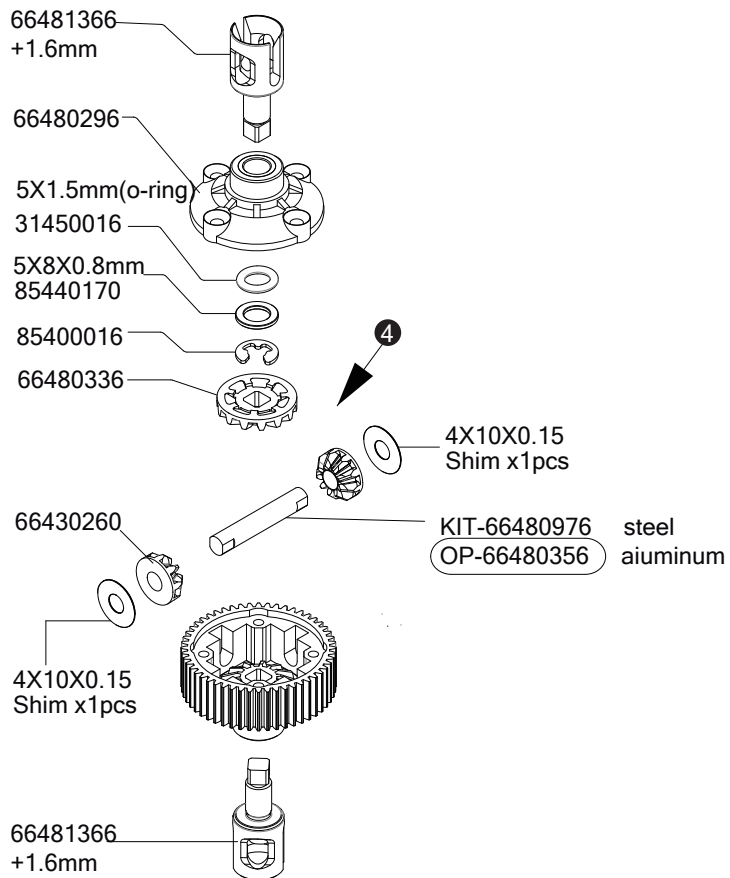



D2 Motor Mounts [Mid Motor]

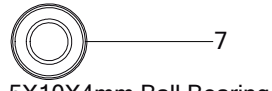

7
5X10X4mm Ball Bearing
89430010

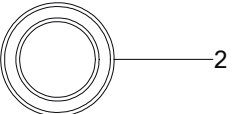

2
10X15X4mm Ball Bearing
89430030

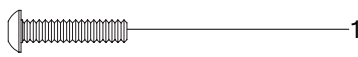

1
3x14mm Button Head Hex Screw
80400056



1
3x20mm Button Head Hex Screw
80400066

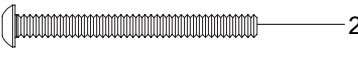

2
3x32mm Button Head Hex Screw
80400086

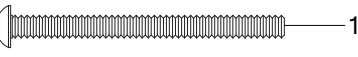

1
3x36mm Button Head Hex Screw
80400096

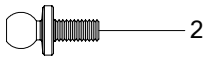

2
M4.8x6mm Ball Studs
68430036

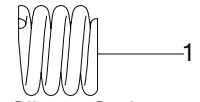

1
Slipper Spring
66480826

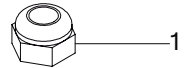

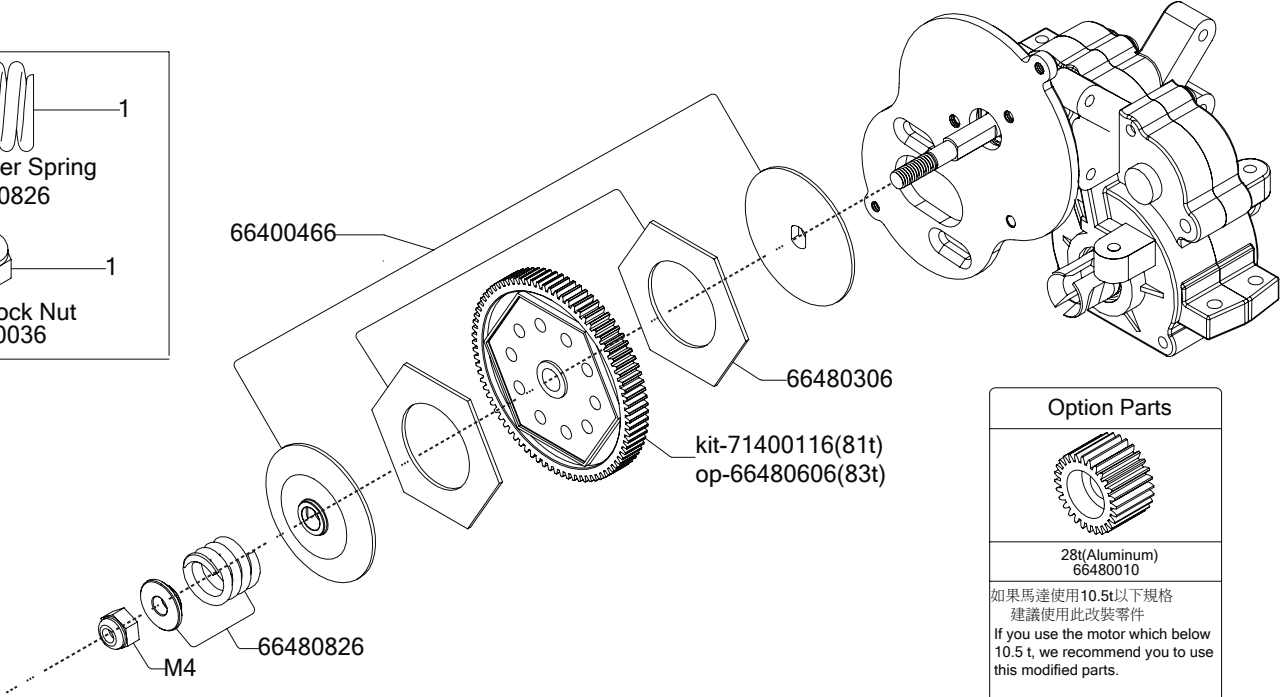
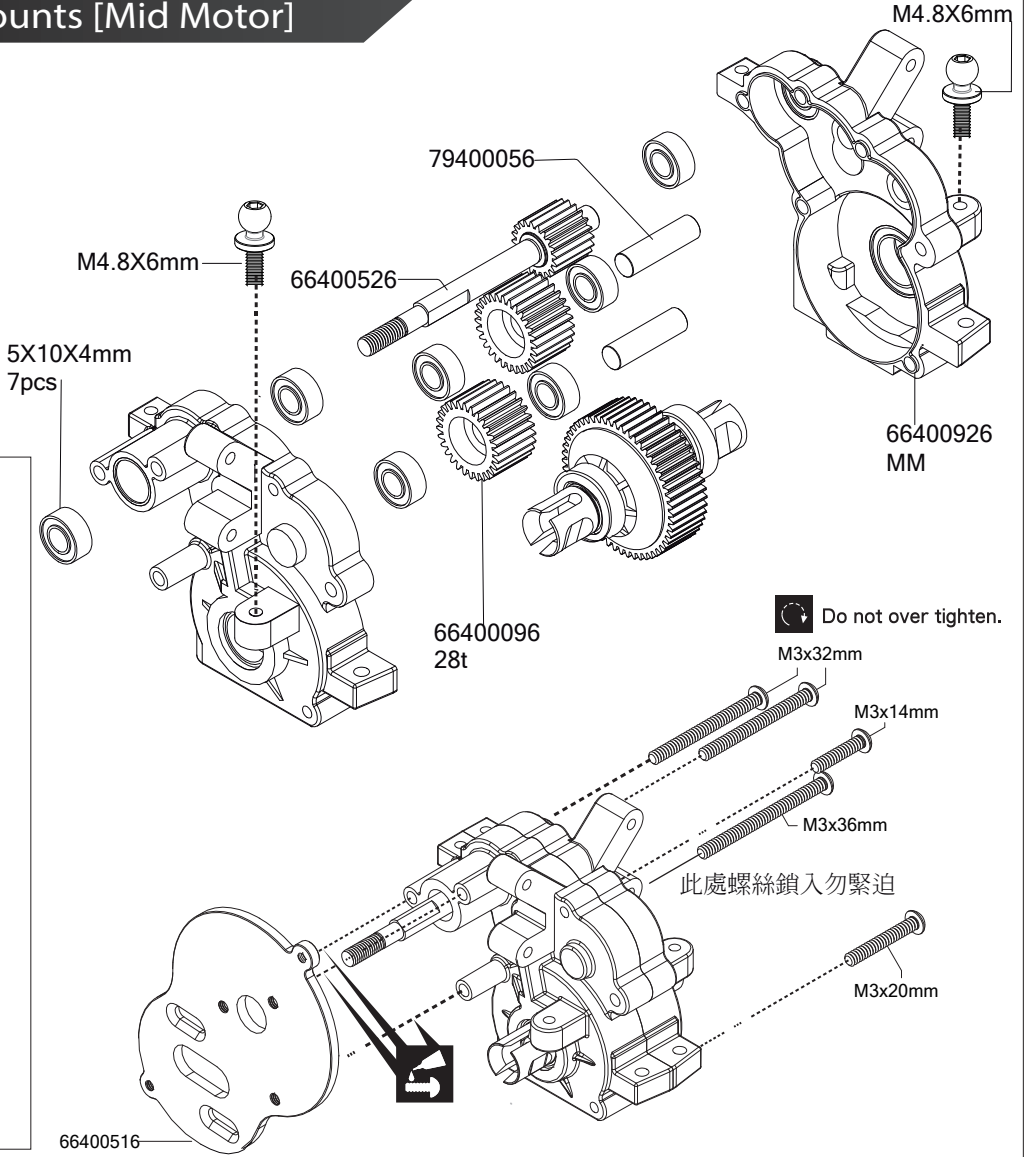

1
M4 Lock Nut
83400036





Option Parts	
28t(Aluminum) 66480010	
如果馬達使用10.5t以下規格 建議使用此改裝零件 If you use the motor which below 10.5 t, we recommend you to use this modified parts.	



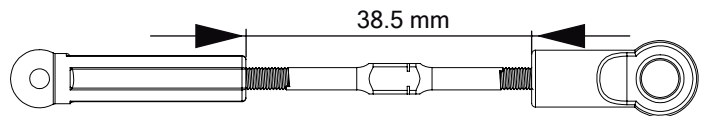
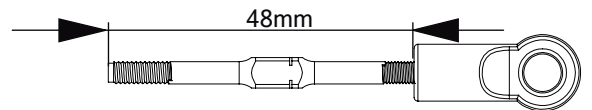
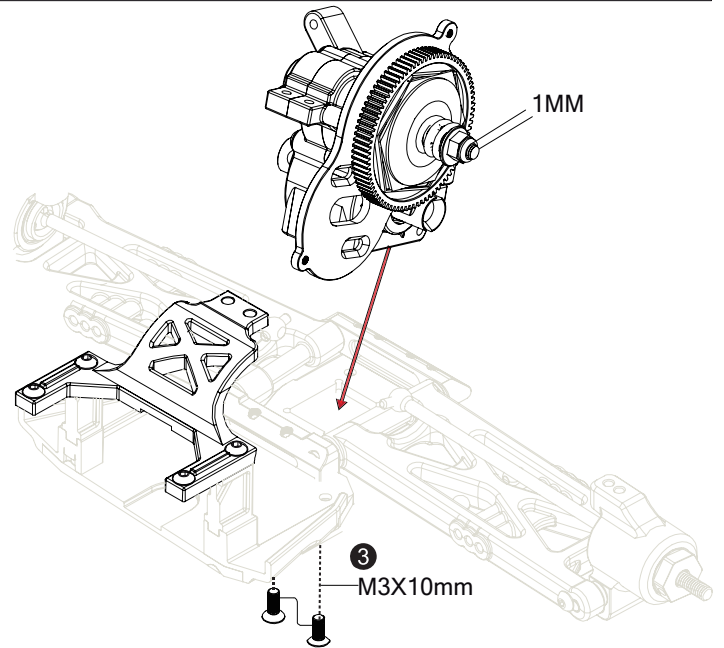
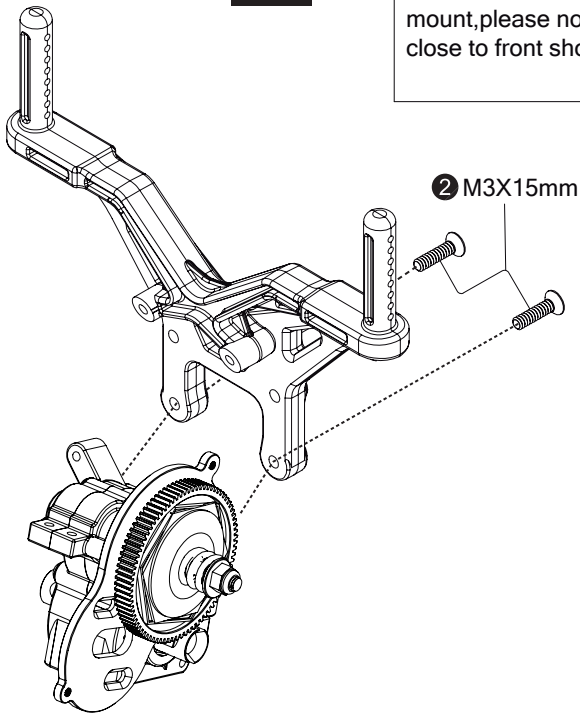
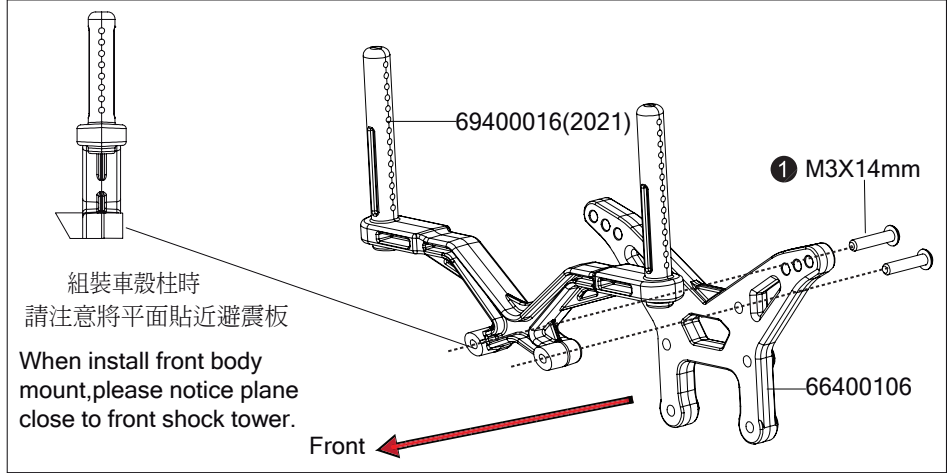

D3 Rear Body Mount Set

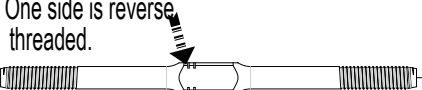
-  2
M3X14mm Button Head Hex Screw
80400056
-  2
M3X15mm Flat Head Hex Screw
82400176



-  2
One side is reverse threaded.
77430066-55mm Turnbuckles
-  2
66401806-Ball Joint

-  2
M3x15 mm Flat Head Screws
82400176
-  2
M3x10 mm Flat Head Screws
82400106

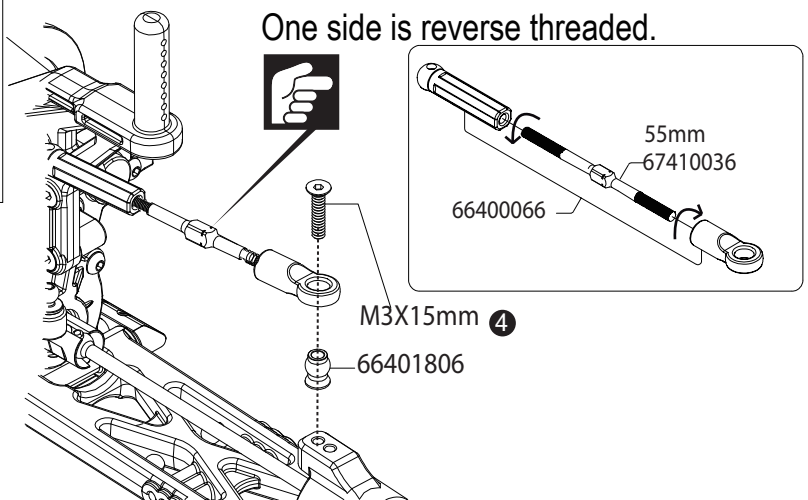



E1 Front & Rear Shock Assembly

Aluminium Shock Kit

Assemble 2 front and 2 rear shocks

1.6mmx2 hole
68410066

Shim
2.6 x6 x0.5mm
85440070

Tighten M2.5 Nut without the use of plier, do not over tighten. Recommend to use the thread lock instead.

m2.5
83400066

Front 77410016 (44mm)

Rear 77410026 (51mm)

31280146
(14X1.2mm) O-Rings

Front 17430156

Rear 17430166

31430016 O-ring (Red)

Shim 0.36mm

31430016 O-ring (Red)

66430070

Front (21.5mm)

Rear (18.5mm)

KIT-68410066
OP-55430076-Black

2:1

KIT-68410066
OP-55430076-White

2:1

KIT-66402106-2 (POM)
OP-66401826 (Steel)

Shim
0.36mm

1.6mmx2
hole

68410066



INCORRECT

EXTREMELY IMPORTANT

Do not push the shock rod straight through the lower shock body assembly; O-ring damage may result.



CORRECT

Twist the shock rod through the lower shock body assembly.

Front

1mm

A Bag 66430200



E1.1

After first drive adjust for track conditions



Front Build x2

450-500 cst

Slowly move up and down to remove air bubbles.

2

Length

Front -27mm
Rear -33.5mm

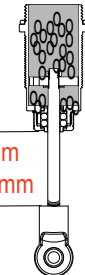

Rear Build x2

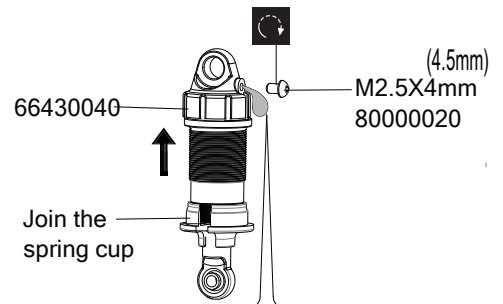

Join the spring cup

3

Slowly push the shock shaft all the way up, wipe away any excess oil that has seeped out, and screw in the bleeder screw.



E1.2

2019 PR 1/10 Type R Shock Spring

71530016-Type R Front Shock Spring Set (Not included-02530016)

PART NO:	Color	kg/mm	lbs/in
02500096	Transparent	0.053	2.97
02500106	Blue	0.058	3.25
02500146	White	0.061	3.42
02500116	Red	0.063	3.53
02500126	Yellow	0.068	3.81
02530016	Green	0.075	4.20
02530026	Black	0.080	4.48
02530036	Blue Red	0.085	4.76
02530046	White Yellow	0.090	5.04
02530116	Green Black	0.098-(RT)	5.88-(RT)
71530026-Type R Rear Shock Spring Set (Not included-02530126)			
02500056	Transparent	0.030	1.80
02500066	Blue	0.035	2.10
02500136	White	0.037	2.22
02500076	Red	0.040	2.40
02500086	Yellow	0.045	2.70
02530056	Green	0.050	3.00
02530066	Black	0.055	3.30
02530076	Blue Red	0.060	3.60
02530086	White Yellow	0.065	3.90
02530126	Green Black	0.073-(RT)	4.50-(RT)

OP



4

Front Build x2

8mm

66430050 Apply oil.

02530036

66400186 Black

19.40 mm

Rear Build x2

11mm

66430050 Apply oil.

02530086

66400186 Black

19.40 mm



Part Bags used.



Apply threadlocker (screw cement)



Do not over tighten.





Apply oil.



Assemble in the specified order.

E2 Front Shock Assembly

BAG
E

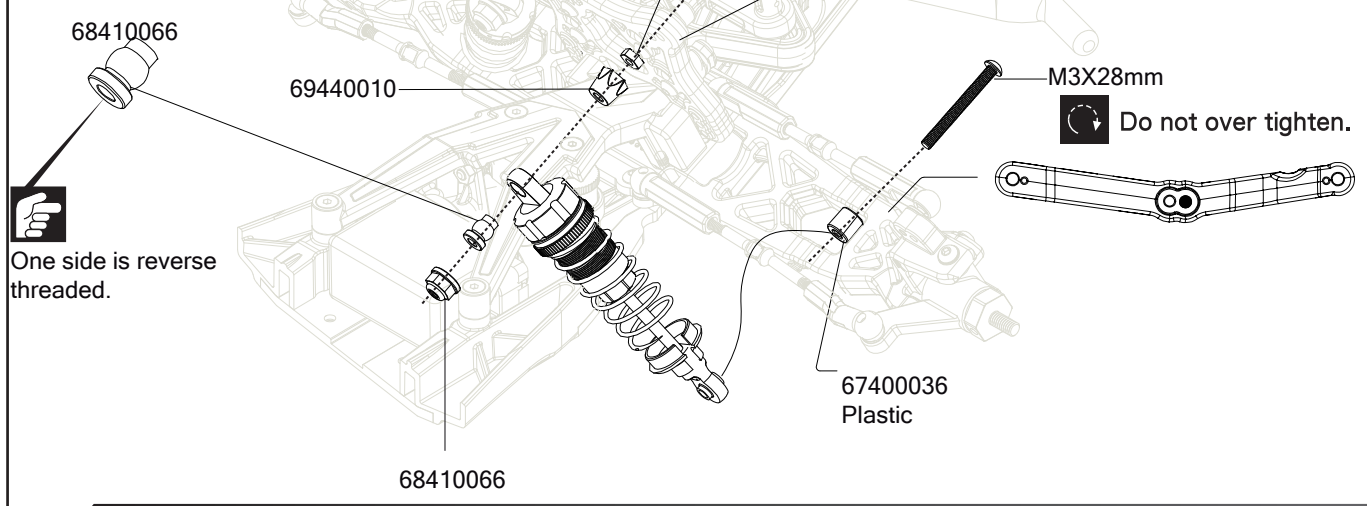
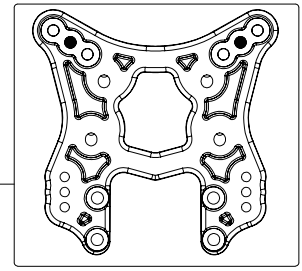

-  4
M3X28mm Button Head Hex Screw
80400126
-  2
83480016
M3 Nut

 Apply threadlocker (screw cement)



E3 Rear Shock Assembly



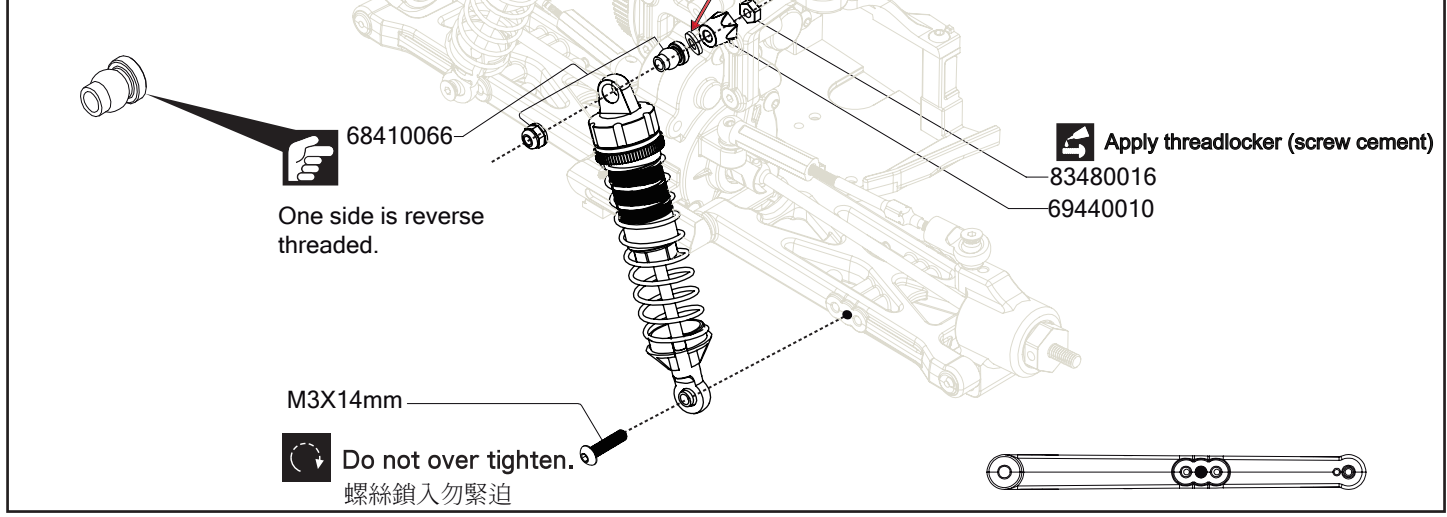
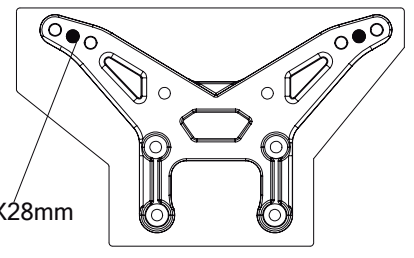
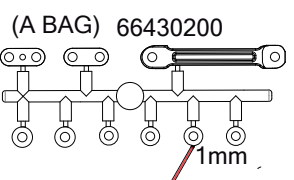

BAG
E

-  2
M3X14mm Button Head Hex Screw
80400056
-  2
M3X28mm Button Head Hex Screw
80400126
-  2
83480016
M3 Nut





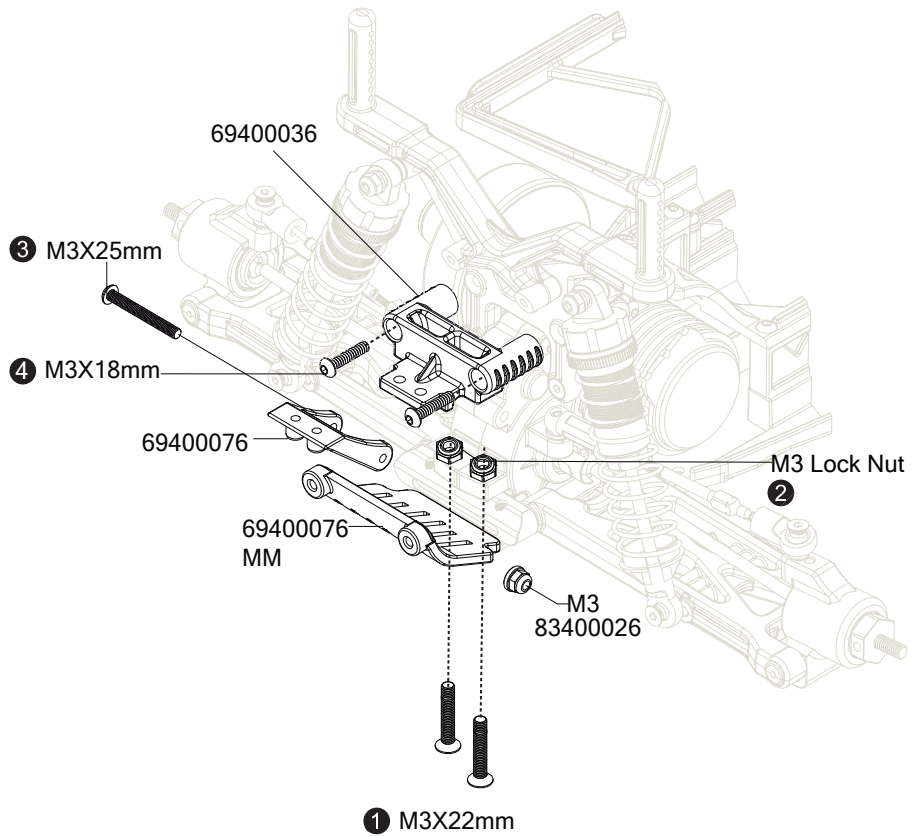

E4 Motor Guard set

-  2
M3X18mm Button Head Hex Screw
82400126
-  1
M3X25mm Button Head Hex Screw
80400076
-  3
M3 Lock Nut-83480026
-  4
M3X22mm Flat Head Hex Screw
82400156



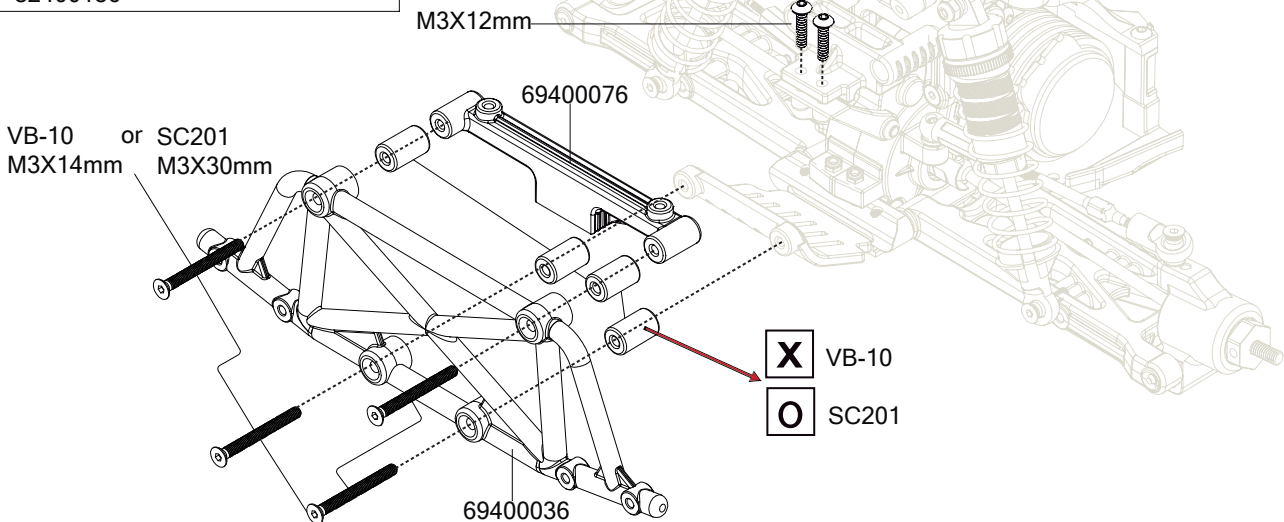

E5 Rear Bumper Set

-  2
M3X12mm Button Head Hex Screw
80400206
-  4
M3X14mm Flat Head Hex Screw
82400046
-  4
M3X30mm Flat Head Hex Screw
82400136







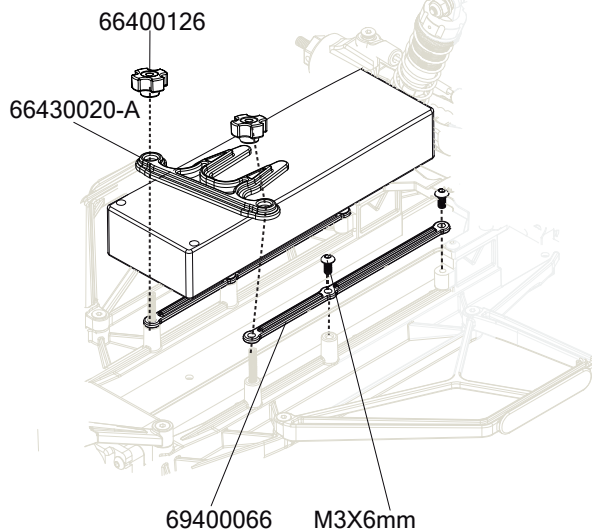
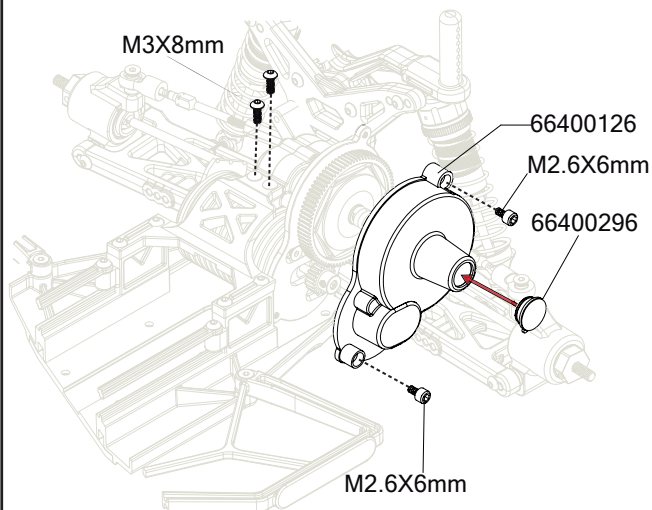

E6 Battery Plate

-  4
M3X6mm Button Head Hex Screw
80400026
-  2
2.6x6mm Cap Screw
87400046
-  4
M3X8mm Button Head Hex Screw
80400036



E7 Battery Plate

-  4
M3X8mm Flat Head Hex Screw
82400026
-  2
M3X6mm Flat Head Hex Screw
82400016
-  4
M3X30mm Flat Head Hex Screw
82400136
-  8
66401926-R6

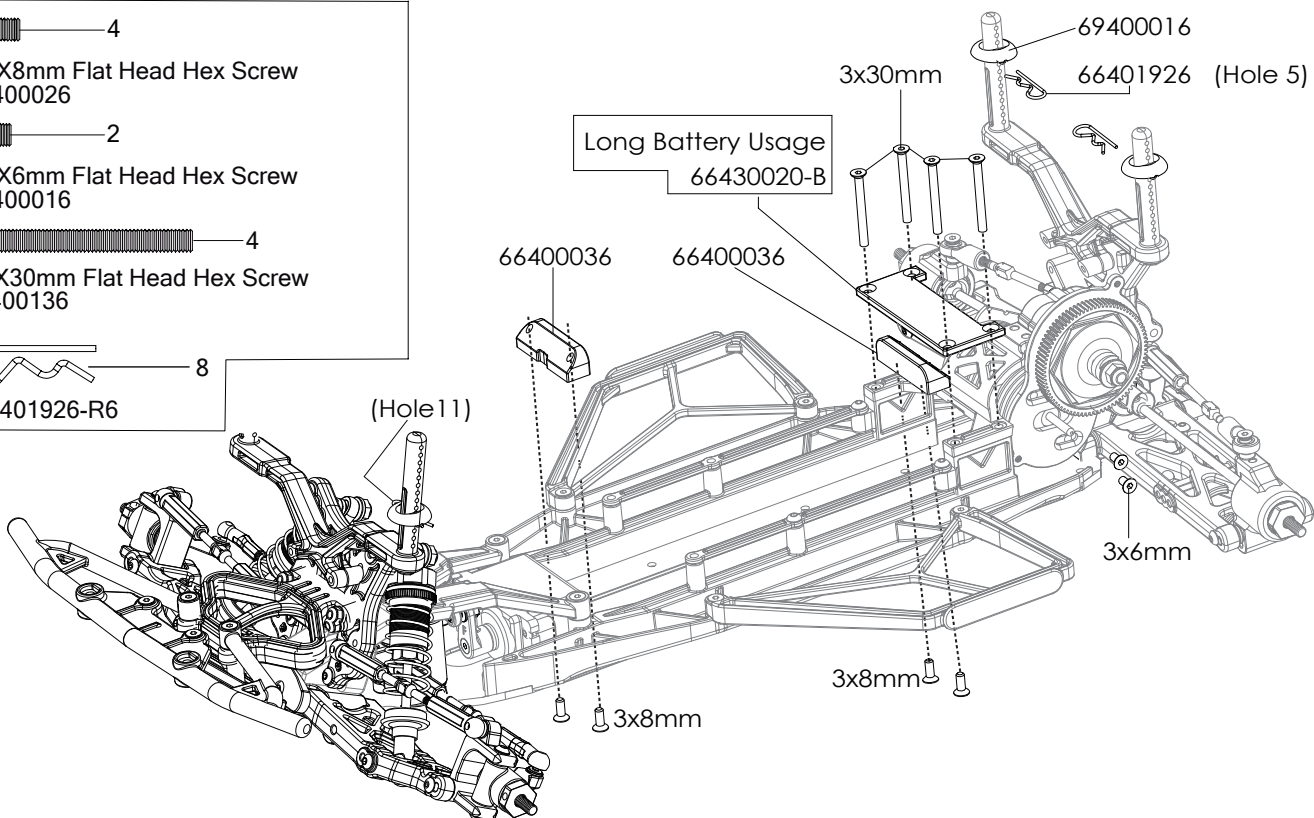



E8 Tires



4

M4 Lock Nut
83400076



4

3X8X0.5mm Shim
85000010



4

M3X8mm Button Head Hex Screw
80400036



4

M3X12mm Button Head Hex Screw
80400206

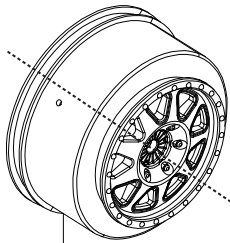
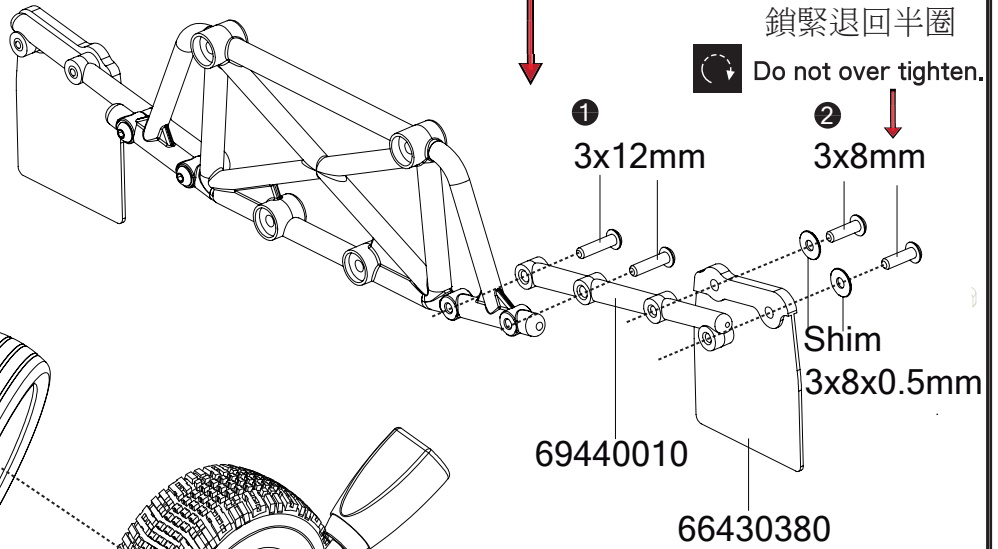
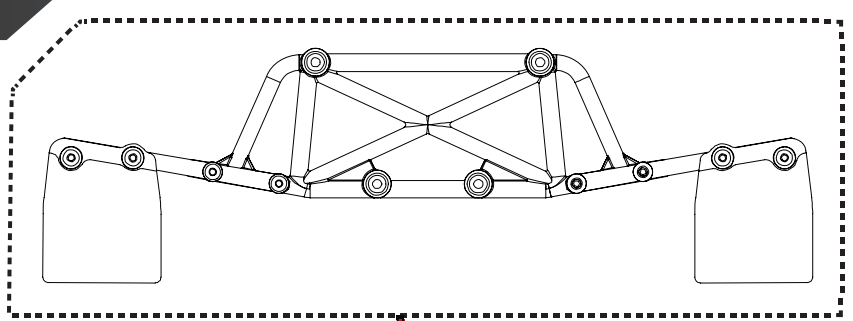

For sc201(Black)
69400136

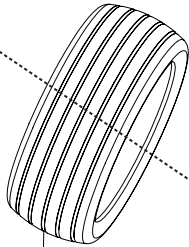

3

33220046

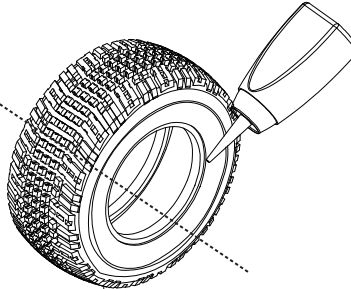

kit-69500036
op-69500026

*Pull the sidewall of the tire slightly away from the rim and apply CA (Cyanoacrylate) glue in between the tire bead and rim

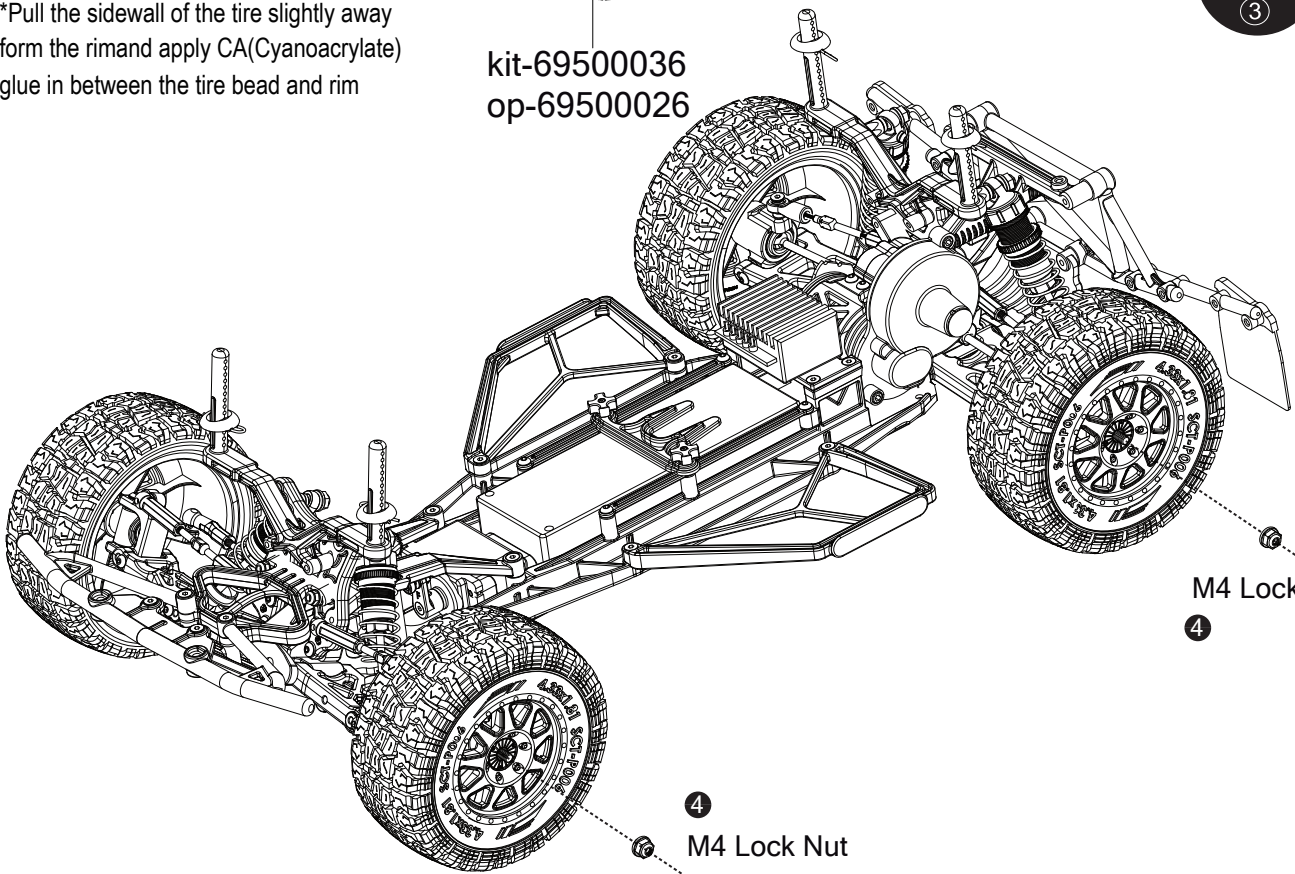

Option Parts: 67000021 – Transmission Assembly set [Rear Motor]

Option Rear Motor

5X10X4mm
Ball Bearing

66400086
Gear Case
(Rear Motor)

10X15X4mm
Ball Bearing

66402016
3 4 T

RM

Gear Case (Rear Motor)
66400086

Option Rear Motor

66400086
Gear Case
(Rear Motor)

66400116

M3
Lock Nut

3x14mm

3x8mm

3x25mm

4mm











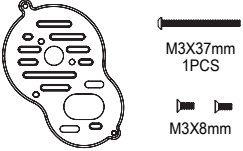
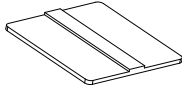
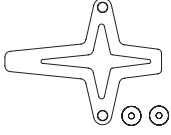
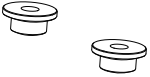

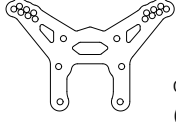
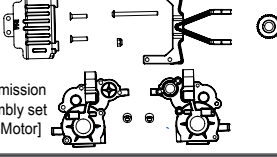
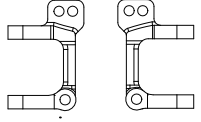
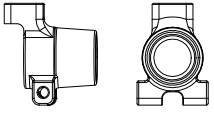
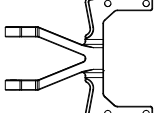
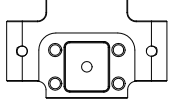
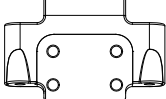
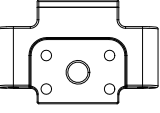
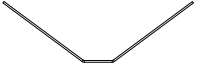
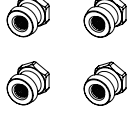

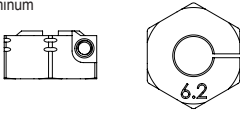
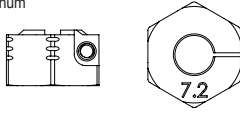
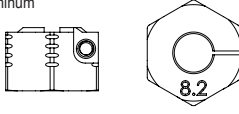
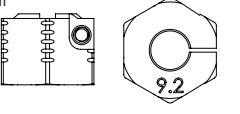
3x32mm

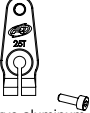
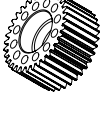
69400076
RM

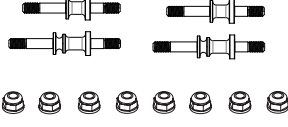
3x10mm

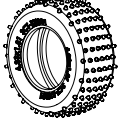
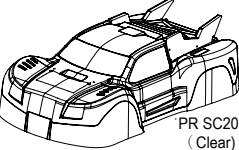
3x22mm

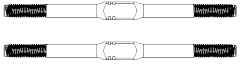
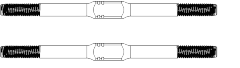
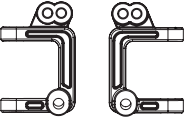
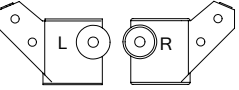

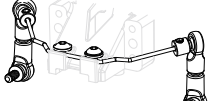
<p>66480386</p>  <p>(1) M3X37mm 1PCS M3X8mm</p>	<p>66480756</p>  <p>Chassis Brass Weight(23g) (1)</p>	<p>66480426</p>  <p>(1) Carbon</p>	<p>00430025</p>  <p>For:Type R Ackerman Steering Knuckle Bushing 3x6mm (2)</p>
<p>66430366</p>  <p>(1) Type R Ackerman board CNC Aluminium-V3</p>	<p>66480256</p>  <p>Carbon (1)</p>	<p>67000021</p>  <p>Transmission Assembly set [Rear Motor]</p>	<p>66480326</p>  <p>S1 Aluminium Caster Block-4 Degree (Pair)</p>
<p>67400146</p>  <p>Aluminum Rear Hub +4mm FOR S1 (CNC)</p>	<p>66480526</p>  <p>S1 V2 Rear reinforcing plate aluminum cnc (1)</p>	<p>66480476</p>  <p>0 Degree Aluminum Lower Swing Arm Mount (+5mm) (1)</p>	<p>66480536</p>  <p>7 Degree Lower Swing Arm Mount (+5mm) 66g (Brass)</p>
<p>66480456</p>  <p>(+5mm 3)lower swing arm mounts 22g (aluminum)</p>	<p>66480736</p>  <p>PR S1 Rear balance beam 1.4mm</p>	<p>66400696</p>  <p>Aluminum Shock Stand off Set - Black - (4)</p>	<p>66480946</p>  <p>Camber Link Brace - Rear - (S1 V2 and V3FM) (1)</p>
<p>90440010</p>  <p>aluminum Wheel Hex -12mm x 6.2mm (2)</p>	<p>90440020</p>  <p>aluminum Wheel Hex -12mm x 7.2mm (2)</p>	<p>90440030</p>  <p>aluminum Wheel Hex -12mm x 8.2mm (2)</p>	<p>90440040</p>  <p>aluminum Wheel Hex -12mm x 9.2mm (2)</p>
<p>23440360</p>  <p>PR RACING Short Nut Driver (5.5mm) (1)</p>	<p>55430086</p>  <p>PR RACING 25T servo aluminum arm For 2wd S1/SC/ST (1)</p>	<p>66480010</p>  <p>For RM PR Racing 34T Aluminium Idler Gear (1)</p>	<p>66402086</p>  <p>28T Aluminum Idler Gear (28T) (1)</p>
<p>81430106</p>  <p>Front Rear Steel Shock Stand off Set</p>	<p>66480606</p>  <p>83T</p>	<p>69500026</p>  <p>Dirt Tires SCT-RX001 (2)</p>	<p>69440050</p>  <p>PR SC201 body+ Sticker (Clear) (1)</p>
<p>77470026</p>  <p>PR VB-10 body+ Sticker (Clear) (1)</p>	<p>77430066</p>  <p>PR SB401R-RT 55mm Turnbuckles steel (2)</p>	<p>77430056</p>  <p>PR SB401R-RT 50mm Turnbuckles steel (2)</p>	<p>66401876</p>  <p>(L/R 3°)</p>
<p>66480856</p>  <p>L R</p>	<p>66480846</p>  <p>2pcs 4pcs(2.5x8mm)</p>	<p>66480040</p>  <p>PR Racing S1 Steel Idler Gear (28T) (2)</p>	<p>66481566</p>  <p>PR Racing SC201 VB-10 front sway bars 1.2mm/1.3mm/1.4mm (1Set) (1)</p>

P R R A C I N G P R R A C I N G

Pinion



66480986	PR Racing 48P Pinion (3.17mm ID) (18T)*1pcs	66481576	PR Racing 48P Pinion (3.17mm ID) (26T)*1pcs
66480996	PR Racing 48P Pinion (3.17mm ID) (19T)*1pcs	66481586	PR Racing 48P Pinion (3.17mm ID) (27T)*1pcs
66481006	PR Racing 48P Pinion (3.17mm ID) (20T)*1pcs	66481596	PR Racing 48P Pinion (3.17mm ID) (28T)*1pcs
66400556	PR Racing 48P Pinion (3.17mm ID) (21T)*1pcs	66481606	PR Racing 48P Pinion (3.17mm ID) (29T)*1pcs
66480096	PR Racing 48P Pinion (3.17mm ID) (22T)*1pcs	66481616	PR Racing 48P Pinion (3.17mm ID) (30T)*1pcs
66480106	PR Racing 48P Pinion (3.17mm ID) (23T)*1pcs	66481626	PR Racing 48P Pinion (3.17mm ID) (31T)*1pcs
66480116	PR Racing 48P Pinion (3.17mm ID) (24T)*1pcs	66481636	PR Racing 48P Pinion (3.17mm ID) (32T)*1pcs
66481566	PR Racing 48P Pinion (3.17mm ID) (25T)*1pcs	66481646	PR Racing 48P Pinion (3.17mm ID) (33T)*1pcs

Spur

66480576	73T Spur Gear (For S1)*1pcs
66480586	75T Spur Gear (For S1)*1pcs
66480596	77T Spur Gear (For S1)*1pcs
71400116	81T Spur Gear (For S1)*1pcs
66480606	83T Spur Gear (For S1)*1pcs

Reference gear ratio

Motor	KV	Reference gear ratio	km/h
8.5T	4600	12.01	53.1
10.5T	3600	10.87	52.9
13.5T	2850	8.91	51
17.5T	2170	6.88	50

 <p>PR S1(Gear Diff) Gear Ratio Chart-Internal Gear Ratio 2.75:1</p>						
	(Gear Diff) Final Drive Ratio	Spur 				
		73	75	77	81	83
Pinion	18					
	19					
	20					11.41
	21					10.87
	22					10.38
	23				9.68	9.92
	24				9.28	9.51
	25				8.91	
	26			8.14	8.57	
	27			7.84	8.25	
	28		7.37	7.56		
	29		7.11	7.30		
	30	6.69	6.88	7.06		
	31	6.48	6.65			
32	6.27	6.45				
33	6.08	6.25				

P R R A C I N G P R R A C I N G

VB-10

PR SC201 MM (VB-10) Off Road 1/10 2WD Short Course Truck Kit



EMAIL / info@prengine.com.tw